

POWERLOCK ENERGY

STORAGE BATTERY STORAGE



- *Microgrids*
- *Energy Storage Systems*
- *Battery Energy Storage Systems*

## A microgrid

- ❖ A part of a larger electrical network that can be controlled by a local operator
- ❖ Consists of conventional and renewable generation units, storage devices and loads
- ❖ Can typically be operated grid-connected and in islanded mode

## Main goals

- ❖ Efficient integration of renewable energy sources
- ❖ Simplify coordination and control tasks in networks with large share of DG units
- ❖ Reduction of energy costs through appropriate energy management
- ❖ Increase reliability within the microgrid

# Microgrids



UNIVERSITY OF LEEDS

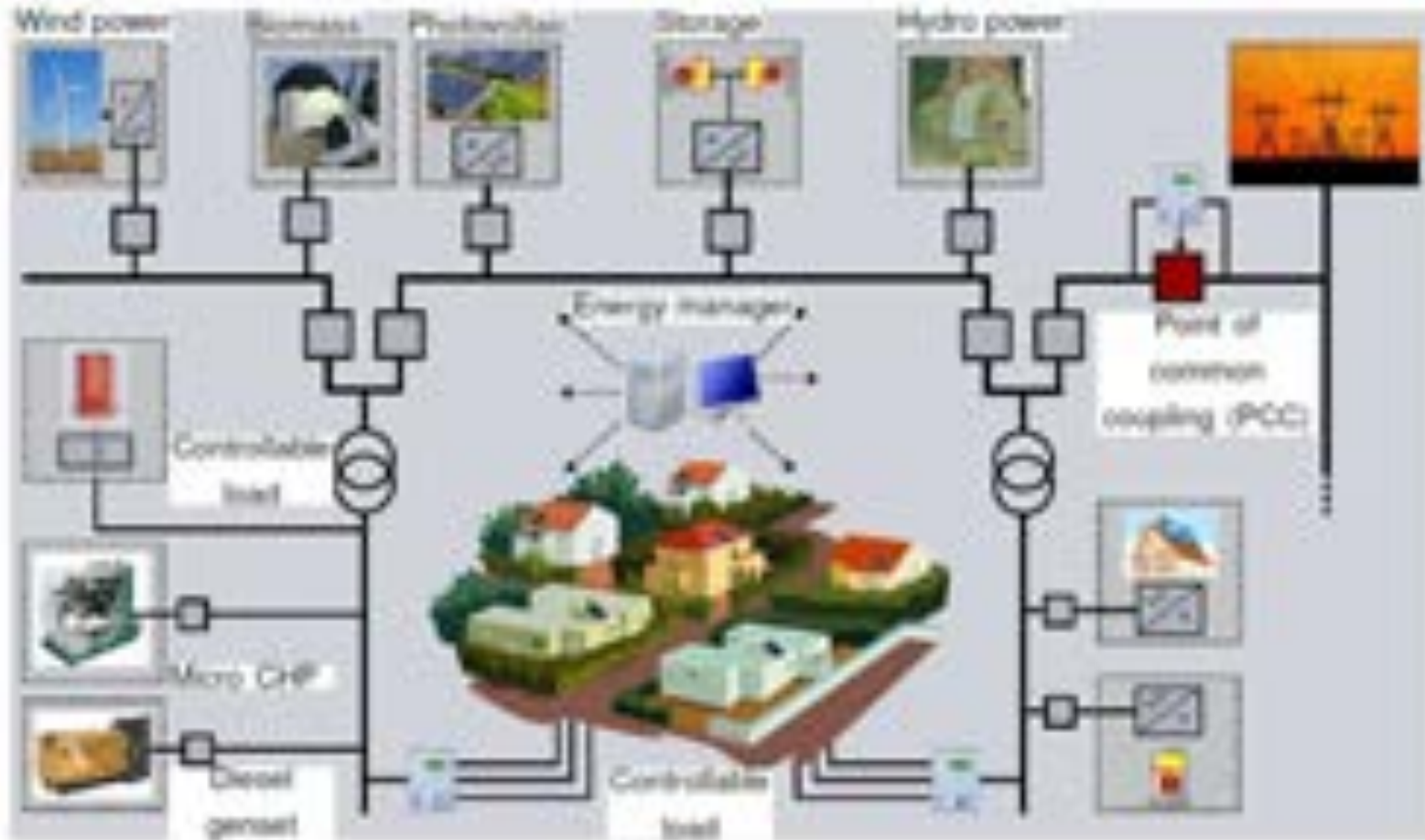

# Microgrids



UNIVERSITY OF LEEDS

## Challenges of integrating distributed renewable generations

<b>Seconds</b>	<i>Renewable generation introduces <b>harmonics</b> and affects power supply quality.</i>
<b>Minutes</b>	<i>Rapid ramping to respond affecting power <b>frequency</b> characteristics.</i>
<b>Hours</b>	<i>Daily <b>peak</b> for electricity is <b>greater</b> to meet demand.</i>
<b>Hours - days</b>	<i>Variability of renewable energy generation needs <b>back-up supply or demand response</b>.</i>
<b>Months</b>	<i><b>Seasonal changes</b> in renewable energy sources and load demands.</i>

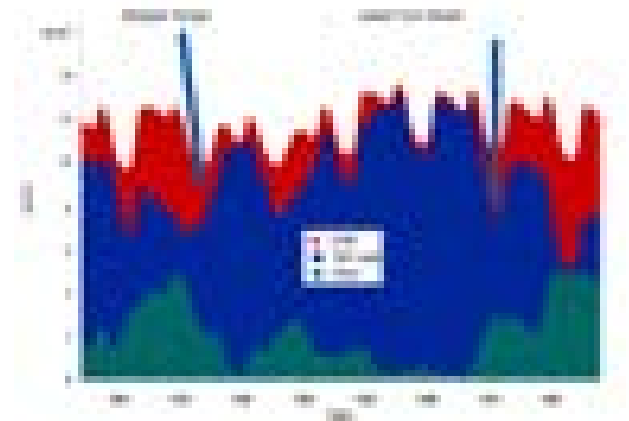

Energy Storage System (ESS) is one of the efficient ways to deal with such issues

# Energy Storage Systems



UNIVERSITY OF LEEDS

## Energy Storage Systems

### Mechanical

- Pumped hydro storage (PHS)
- Compressed air energy storage (CAES)
- Flywheel

### Electrical

- Double layer capacitor (DLC)
- Superconducting magnetic energy storage (SMES)

### Electrochemical

- **Battery energy storage systems (BESS).**

### Chemical

- Fuel cell
- Substitute nature gas

### Thermal

- Sensible heat storage

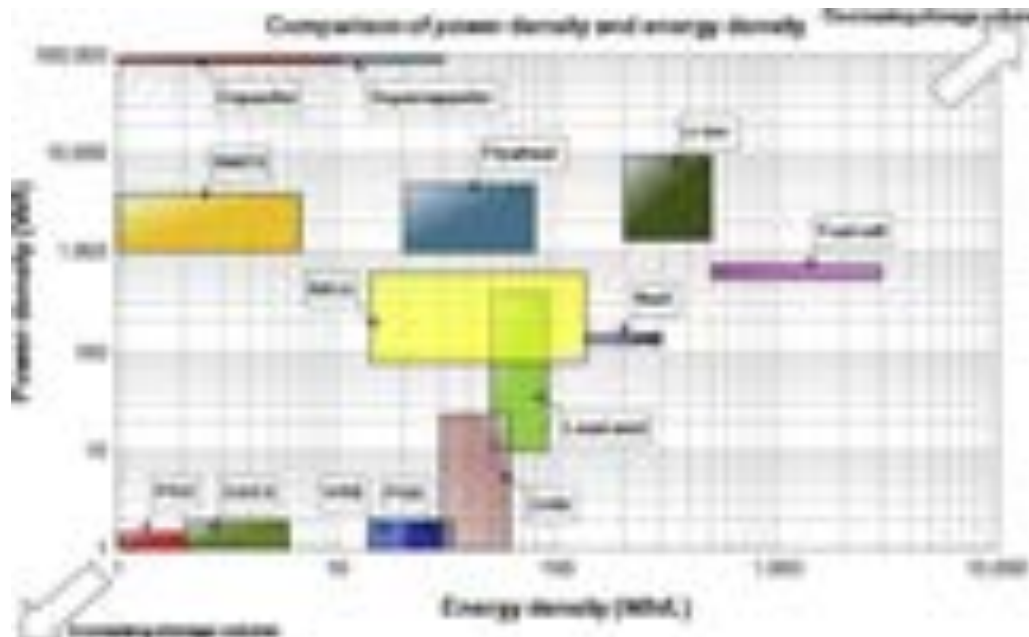

# Energy Storage Systems



UNIVERSITY OF LEEDS

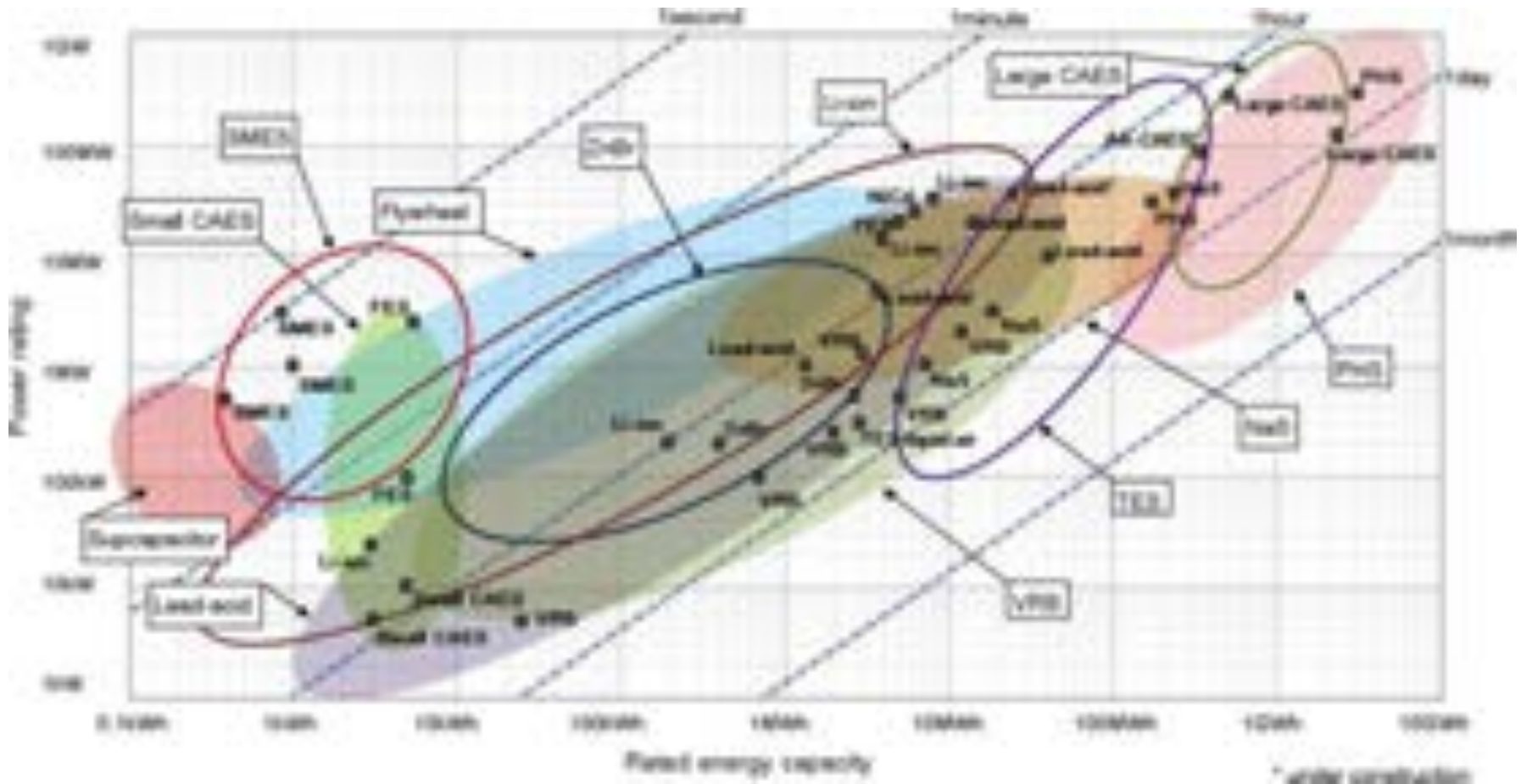

# Battery Energy Storage Systems

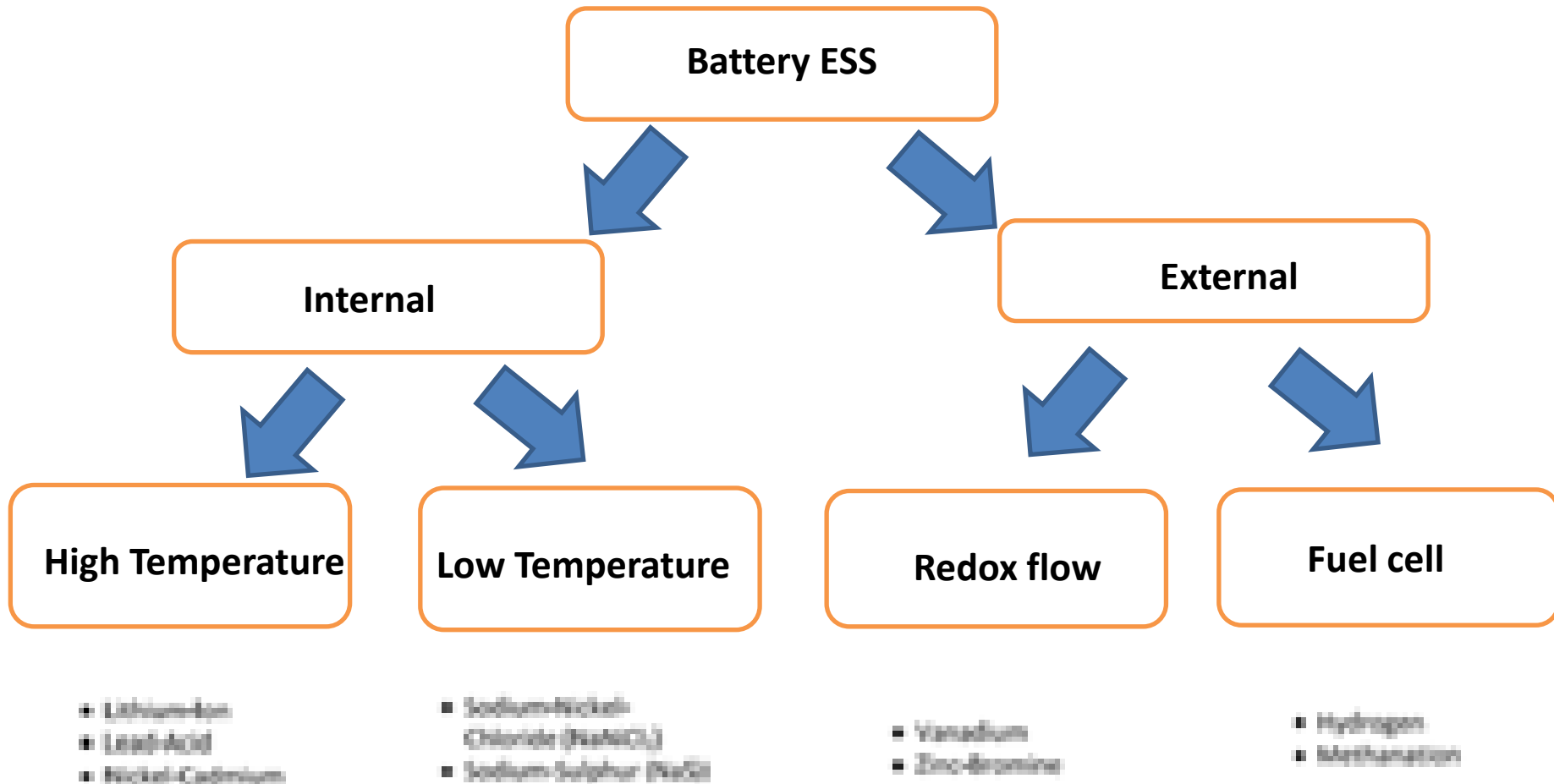

# Battery Energy Storage Systems



UNIVERSITY OF LEEDS

## Comparison of several popular battery technologies

	Gravimetric energy density (Wh/kg)	Gravimetric power density (W/kg)	Volumetric energy density (Wh/L)	Volumetric power density (W/L)	Nominal cell voltage (V)	Charging Temperature (°C)	Discharging Temperature (°C)	Daily Self-Discharge rate (%)	Lifetime (Years)	Cycle life (Cycles)	Environment impact
Lead-acid battery	30 - 50	75 - 300	50 - 90	10 - 400	2	-20 - 50	-20 - 50	0.05 - 0.3	5 - 15	500 - 2000	Serious
Ni-Cd battery	50 - 75	150 - 300	60 - 150	75 - 700	1.2	0 - 45	-20 - 65	0.2 - 0.6	15 - 20	1500 - 3000	Serious
Ni-MH battery	54 - 120	200 - 1200	190 - 490	500 - 3000	1.2	0 - 45	-20 - 65	1 - 2	15 - 20	1500 - 3000	Medium
Zebra battery	100 - 120	150 - 200	150 - 180	220 - 300	2.58	270 - 350	270 - 350	10 - 15	10 - 20	>25000	Slight
<b>Lithium-ion battery</b>	<b>150 - 250</b>	<b>500 - 2000</b>	<b>400 - 650</b>	<b>1500 - 10,000</b>	<b>3.3 - 3.7</b>	<b>0 - 45</b>	<b>-20 - 60</b>	<b>0.1 - 0.3</b>	<b>8 - 15</b>	<b>1000 - 10,000</b>	<b>Slight</b>

	Energy density	Efficiency (%)	Life Cycle	Cost	Safety issue
Lead-Acid	Low	85-90	500-1000	Low	Toxic/ Pollution
Lithium-ion	High	87-92	1000-	High	Potential Fire Hazard
NaS	High	75	2500	Low	Potential Fire Hazard
VRB	Low	65-75	10000+	High (Expensive Membrane Required)	V(V <sup>5+</sup> ) is Toxic
Single flow ZNB	Low	65-85	5000-10000	Low (Abundant and cheap materials )	Ignored

# Battery Energy Storage Systems



UNIVERSITY OF LEEDS

## Lithium-ion battery

- The operation mechanism is based on the movement of lithium-ions.
- Cathode: layered structure of lithium cobalt oxide ( $\text{LiCoO}_2$ ), Nickel manganese acid, lithium ternary material ( $\text{Li (Ni, Co, Mn) O}_2$ ), spinel-structure lithium manganese oxides, olivine-type lithium iron phosphate and other lithium manganese oxide
- Anode: Carbonaceous materials (graphite, graphene, et), alloy/de-alloy materials such as Si, Sn, Al, Mg, etc.; and conversion reaction materials such as metal oxides ( $\text{Fe}_3\text{O}_4$ ,  $\text{Co}_3\text{O}_4$ ,  $\text{Fe}_2\text{O}_3$  etc.)

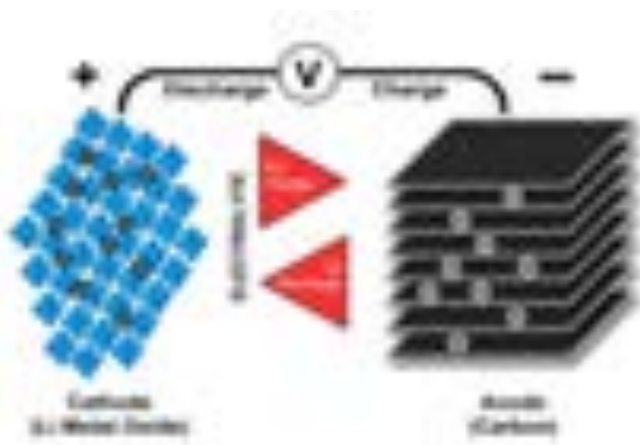

Global Lithium-ion Battery Market Size and Forecast, 2022 - 2028 (USD Billion)



# Battery Energy Storage Systems



UNIVERSITY OF LEEDS

## Redox flow battery

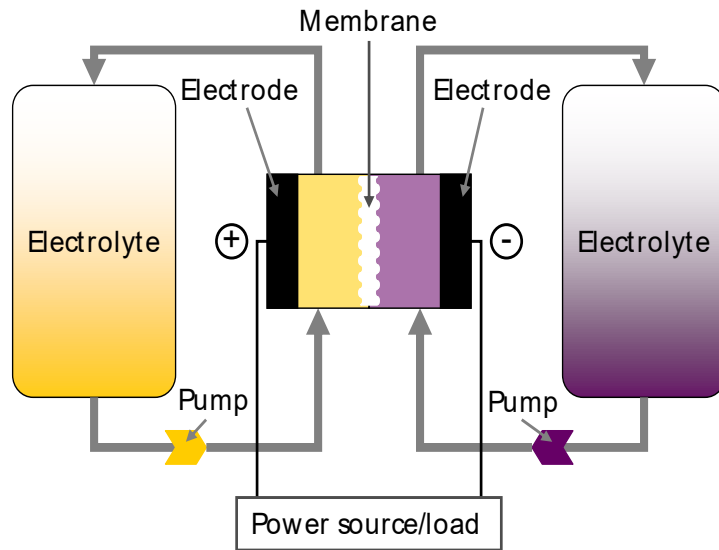

- Separated electrolyte and stacks - stored capacity and the rated power
- Easy to scale up
- Cost friendly
- Extremely safe
- Fast respond speed
- Easy to install and control



Small-size RFB



Large-scale RFB

# Battery Energy Storage Systems



UNIVERSITY OF LEEDS

## BESS applications in grid

### Generation Level

- Renewable energy integration
- Peak shaving
- Price arbitrage
- Frequency regulation
- Spinning reserve

### Transmission and Distribution Level

- Network investment deferral
- Black-start
- Voltage support
- Congestion relief

### End-user Level

- Power quality and reliability
- Demand side energy management

# Battery Energy Storage Systems

## Generation Level

- Renewable energy integration
- Peak shaving
- Price arbitrage
- Frequency regulation
- Spinning reserve

- Damping the variability of the renewable energy system and providing time shifting.
- *Duration of wind integration: 15 minutes (voltage support), 5 – 10 hours (off-peak storage)*
- *Duration of PV integration: 15 minutes – 4 hours.*

- Avoid the installation of capacity to supply the peaks of a highly variable load
- BESS can provide fast response (**milliseconds**) and emission-free operation.
- Reducing the need for peaking units.

- Time shift: Charging the BESS during periods when the prices or system marginal costs are low, the stored energy can be used or sold at a later time when the price or cost are high.
- BESS operating cost and storage efficiency are especially important for this application.

- The BESS is charged or discharged in response to an increase or decrease of grid frequency and keeps it within pre-set limits (49.5 – 50.5Hz).
- BESS can provide fast response to meet the Primary (10 – 30s), secondary (30s – 30min) and high (10s) frequency response.

- The BESS is maintained at a specific SOC level ready to respond to a generation outage.
- Depending on the application, the BESS can respond within milliseconds or minutes.

# Battery Energy Storage Systems



UNIVERSITY OF LEEDS

## Transmission and Distribution Level

- Network investment deferral
- Black-start
- Voltage support
- Congestion relief

- By reducing peak load growth, BESS defer the transmission upgrade investments.
- BESS discharges when the load is over the current transmission line capacity.
- BESS can be used to provide enough incremental capacity to defer the need for a large lump investment in transmission equipment.

- BESS provides active reserve of power to energize transmission and distribution lines.
- BESS also can provide the electricity for the power plant to perform start-up operations.

- BESS provides reactive support to the grid with the change of its power factor to **compensate the reactive power flows** on the grid.

- BESS would be installed at locations where are electrically downstream from the congested portion of the transmission system.
- Energy would be stored when there is no transmission congestion, and it would be discharged (during peak demand periods) to reduce peak transmission capacity requirements.

# Battery Energy Storage Systems

## End-user Level

- Power quality and reliability
- Demand side energy management

- BESS can effectively support customer loads when there is a total loss of power from the source utility.
- This support requires the storage system and customer loads to island during the utility outage and resynchronize with the utility when power is restored.

- BESS can be used to reduce the overall costs for electric service by reducing the demand during peak periods.
- Through load shifting with BESS, customer can reduce their demand charges and avoid demand charge penalties.

# Battery Energy Storage Systems



UNIVERSITY OF LEEDS

## Voltage Characteristics (LV&MV)

Parameter	Supply voltage characteristics (According to EN 50160)
Voltage magnitude variations	LV: $\pm 10\%$ of the Nominal voltage of the system MV: $\pm 10\%$ of the Nominal voltage of the system
Rapid voltage changes	LV: 5% (normal) and 10% (infrequently) MV: 4% (normal) and 6% (infrequently)
Supply voltage dips	Majority: duration $< 1s$ , depth $< 60\%$ Locally limited dips caused by load switching on: LV: 10 – 50 % MV: 10 – 15%
Short interruptions of supply voltage	LV & MV: Up to 3 minutes
Supply voltage unbalance	LV & MV: Up to 2%. (3% in some locations)

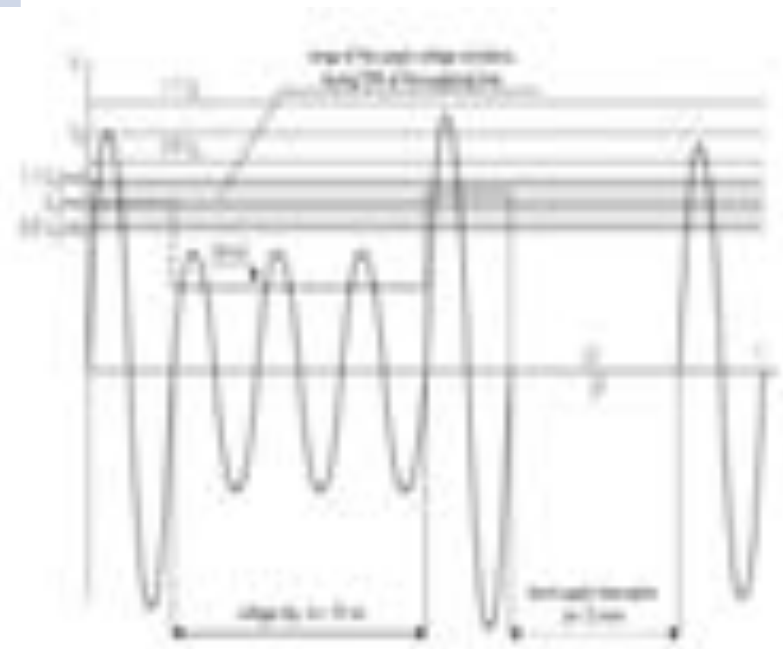

Illustration of a voltage dip and a short supply interruption

## Frequency Grid Code for BESS

- The grid-connected BESSs can be identified as **generating facilities** when they operate at the electricity generation mode.
- The BESS is required to provide a certain level of power output in the case of frequency deviations. The **nominal frequency interval is 49.5 – 50.5 Hz** and the **critical frequency interval is 47.0 – 52.0 Hz**.
- For onshore synchronous generating units (when supplying rated MW), they must be capable of continuous operation at any point **between the limits of 0.85 power factor lagging and 0.95 power factor leading** at the generating unit terminals.
- For onshore non-synchronous generating units must be capable of **maintaining zero transfer of reactive power** at the onshore grid entry point at all active power output levels under steady state voltage conditions. The steady state tolerance on reactive power transfer to and from the network should be **no greater than 5% of rated MW**.

Frequency ranges (Hz)	Operation period requirements
51.5 – 52.0	At least 15 minutes is required for each time.
51.0 – 51.5	At least 90 minutes is required for each time.
49.0 – 51.0	Continuous operation is required.
47.5 – 49.0	At least 90 minutes is required for each time.
47.0 – 47.5	At least 20 seconds is required for each time.

The requirements of generating units regarding the GB grid frequency variations [4]

## Frequency Control Strategies

- **Mandatory Frequency Response:** an automatic change in active power output in response to a frequency change. The service is needed to maintain the frequency within statutory (49.5 – 50.5Hz) and operational limits (49.8 – 50.2 Hz).
- **Primary Response:** Provision of additional active power within 10 seconds after an event and can be sustained for a further 20 seconds.
- **Secondary Response:** Provision of additional active power within 30 seconds after an event and can be sustained for a further 30 minutes.
- **High Frequency Response:** the reduction in active power within 10 seconds after an event and sustained indefinitely.



# Battery Energy Storage Systems

## Challenges

- **Safety Issues:**

For safe and secure operations, various factors, such as life cycle, operating temperature, short-circuit problem, overcharging, over-discharging characteristics must be addressed efficiently.

- **BESS size determination:**

Sizing of the energy storage system is critical in microgrid design. A number of factors should be considered when determining the size of BESS for microgrids.

- **Energy Management System:**

To design an efficient Energy Management System, the minimisation of the overall system loss and the control of SOC can play a vital role in optimising the efficiency and keeping the reserve for future demand.



Battery swelling caused by overcharging

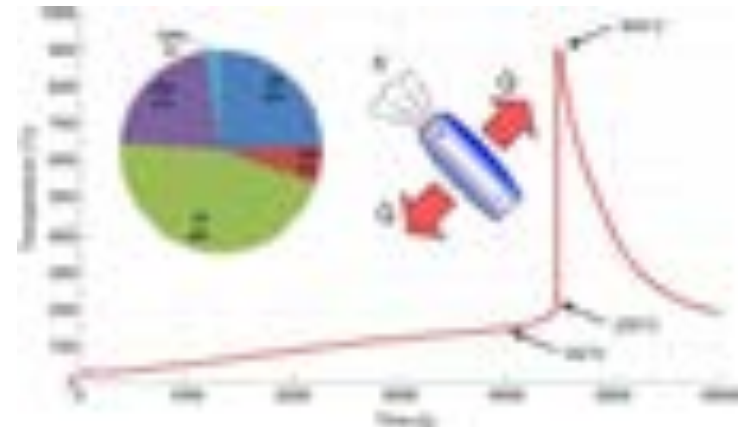

Lithium-ion battery thermal runaway.



## Battery safety issues

### Safety issues caused by undesirable chemical reactions:

- At high-temperature and high-voltage conditions, the electrochemical reactions inside the cell become more complex, including decomposition of the solid electrolyte interface (SEI) film, oxygen release at the cathode side, and additional electrolyte/electrode parasitic side reactions.
- SEI film decomposition and interfacial reactions initially accelerate the temperature increase, thereby increasing risks of oxygen release from the active cathode materials. These reactions eventually lead to lithium-ion battery thermal runaway, which causes battery rupture and explosion due to the reaction of hot flammable gases from the battery with the ambient oxygen.

### Safety issues caused by mechanical abuse:

- Due to the high energy density of lithium-ion batteries, local damage caused by external influences will release a significant amount of heat, which can easily cause thermal runaway.
- The distribution of internal stresses in certain areas of the battery could cause internal short circuits.
- Cell damage by squeezing deformation can tear the separator, causing the electrodes to come into direct contact.

## Battery safety issues

### Safety issues induced by electrical abuse:

- Overcharge is the most dangerous types of electrical abuse and one of the most frequently observed reasons for lithium-ion battery safety accidents.
- Overcharge can cause electrolyte decomposition, heat and gas generation during the side reactions.
- Charging rate is often the most significant factor affecting overcharge, as the overcharging current density determines the rate of heat generation by the battery reactions: the higher the current, the more heat is generated per unit time, increasing the risks of uncontrollable battery behaviour.

### Safety issues caused by thermal abuse:

- In thermal abuse situations, a battery experiences thermal shock, or its local temperature is too high.
- The combustibles in the vicinity may ignite if they are close to or in contact with a hot battery.
- The heat dissipation of a cell depends on its external surface area and geometry. Heat dissipation by radiation helps to alleviate some of the generated heat, but some of the heat remains stored inside the battery. If this heat continues to accumulate instead of being dissipated, exothermic side reactions start to occur, further concentrating thermal stress, causes thermal runaway.

## Battery safety issues

Safety issues caused by undesirable chemical reactions

Safety issues caused by mechanical abuse

Safety issues induced by electrical abuse

Safety issues caused by thermal abuse

### Thermal Runway

- Thermal runaway is the most detrimental lithium-ion battery safety issue.
- The origins of thermal runaway including side reactions of electrolyte, cathode, anode, and interfacial reactions at the surface of electrodes and Li plating.
- The temperature of a lithium-ion cell is determined by the heat balance between the amount of heat generated and that dissipated by the cell. When a cell is heated above a certain temperature (usually above 130–150 °C), exothermic chemical reactions between the electrodes and electrolyte set in will raise its internal temperature.
- If the heat generated is more than what can be dissipated, the exothermic processes would proceed under adiabatic-like conditions and the cell's temperature will increase rapidly.
- The rising temperature will further accelerate the chemical reactions, rather than the desired galvanic reactions, causing even more heat to be produced, eventually resulting in thermal runaway.

## Battery energy storage system size determination

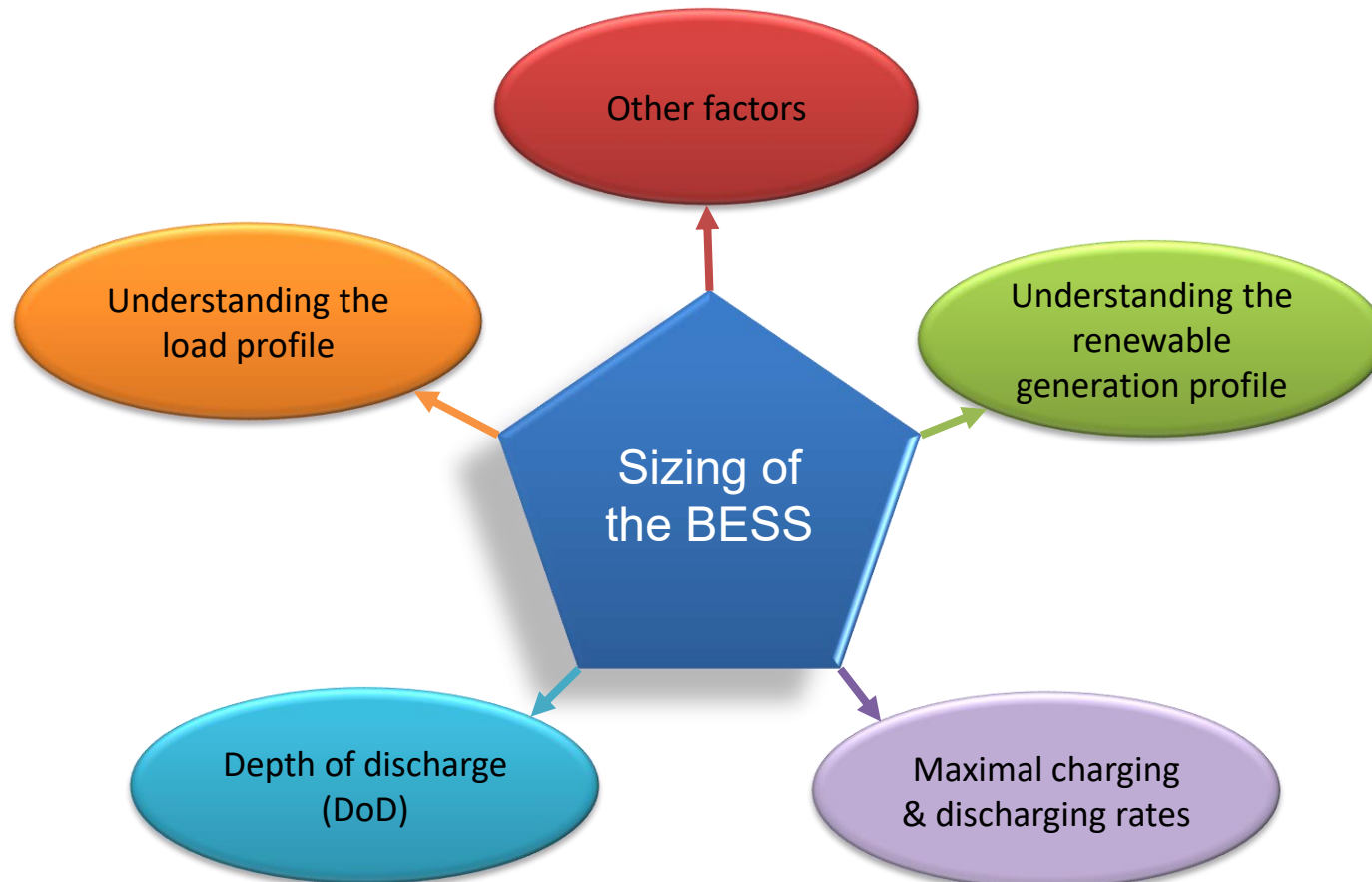

# Battery Energy Storage Systems



UNIVERSITY OF LEEDS

Understanding the  
load profile

The load profile is variable in days and seasons. Hence it is necessary to calculate or collect the load demand data and analyse the distributions and boundaries of the load profile across different days and seasons, and calculate the mean and variance of the load profile during a day.

Understanding the  
renewable  
generation profile

The uncertainties and intermittence nature of the renewable generation impose challenges on estimation of generation profile. Using the procedure for load profile investigation, it is still possible to roughly estimate the generation profiles across different days and sessions.

# Battery Energy Storage Systems



UNIVERSITY OF LEEDS

Depth of discharge  
(DoD)

DoD decides the usable energy storage. If the DoD exceeds the threshold, the battery life will be significantly reduced.

Maximal charging  
& discharging rates

This determines the capacity of BESS such that the battery bank will not exceed the maximum continuous charge and discharge rate for specific applications to prevent damage and potential safety hazard and dramatic degradation of battery life.

Other factors

e.g. battery operating temperature, duty cycle, battery aging, providing network services, etc.

## Sizing criteria – Financial Indicators

### Overall costs and benefits of the BESS (over the operational lifetime):

- Determine the overall costs of a BESS on a lifetime basis, including levelized upfront capital costs, annual/daily operation and maintenance costs, etc.
- The indicator to be optimized can be the **Net Present Value (NPV)** of the system (which should be maximized) or the **levelized cost of electricity (LCOE)** on annual/daily basis (which should be minimized).

### Maximizing the market benefit of the microgrid:

- The total benefits in grid-connected mode are maximized and the total costs associated with being in islanded mode are minimized.
- The total costs of microgrids include the levelized operating costs from BESS and other running components.
- The total benefits are calculated through the difference between the benefits from selling electricity and the total operating costs.

## Sizing criteria – Technical indicators

- In the optimization, technical indicators can be quantified by binary variables, i.e. do they meet or not meet the requirements, or as a specific value goal.
- Technical indicators generally act as constraints within which the financial indicators need to be optimized.
- Some of the most considered battery constraints include:

➤ Power limits: 
$$\begin{cases} 0 \leq P_c(t) \leq P_{c,max} \\ 0 \leq P_d(t) \leq P_{d,max} \end{cases}$$

➤ Energy limits :  $E_{min} \leq E(t) \leq E_{max}$

➤ SOC limits:  $SOC_{min} \leq SOC(t) \leq SOC_{max}$

## Example of battery storage requirement calculation – system modelling

- **Wind power:**

$$P_w = \begin{cases} 0 & v \leq v_c \text{ or } v \geq v_f \\ p_r * \frac{v^k - v_c^k}{v_r^k - v_c^k} & v_c \leq v \leq v_r \\ p_r & v_r \leq v \leq v_f \end{cases}$$

where  $v$  is wind speed,  $v_c$  is the cut-in wind speed,  $v_r$  is the rated wind speed,  $v_f$  is the cut-off wind speed.  $p_r$  is the rated electrical power.  $P_w$  is the wind power generation output.

- **Solar power:**

$$p_s = \eta SI(1 - 0.005(t_0 - 25))$$
$$MAPE = \frac{1}{N} \sum_{i=1}^N \left| \frac{I_f^i - I_a^i}{I_a^i} \right| * 100\%$$

where  $p_s$  is the solar photovoltaic power output,  $\eta$  is the conversion efficiency of the solar cell array (%),  $S$  is the array area ( $m^2$ ),  $I$  is the solar radiation ( $kW/m^2$ ) and  $t_0$  is the outside air temperature ( $^{\circ}C$ ).  $I_f$  and  $I_a$  are the forecasted and actual radiation, respectively.  $N$  is the data size.  $MAPE$  is the mean absolute percentage error that used to express the difference between the actual and forecasted radiation.

# Battery Energy Storage Systems



UNIVERSITY OF LEEDS

## Example of battery storage requirement calculation – system modelling

- **Microturbines and Fuel Cells:**

$$C(P) = a + bP$$

where  $C(P)$  is total cost of microturbines (installation cost and fuel cost),  $a$  and  $b$  are the cost coefficients.

- **Battery Energy Storage System:**

$$C(t + 1) = \begin{cases} C(t) - \Delta t P_t^{E,d} / \eta_d & \text{for discharge} \\ C(t) + \Delta t P_t^{E,c} \eta_c & \text{for charge} \end{cases}$$

where  $C(t)$  is the energy stored in the battery bank at time  $t$ .  $P_t^{E,d}$  is the power discharged by the battery bank,  $P_t^{E,c}$  is the power charged by the grid to the battery bank.  $\Delta t$  is the duration time of each interval.  $\eta_d$  and  $\eta_c$  are the discharge efficiency and charge efficiency, respectively. The battery bank should also satisfy the following constraints:

$$\text{Power limits: } \begin{cases} 0 \leq P_t^{E,d} \leq P_E^{d,max} \\ 0 \leq P_t^{E,c} \leq P_E^{c,max} \end{cases}$$

$$\text{Stored energy limits: } C_{min} \leq C(t) \leq C_{max}$$

## Example of battery storage requirement calculation – system modelling

- The cost of BESS includes the one-time cost and the annual maintenance cost.
- The on-time cost (includes the purchase of batteries and their installation) is a variable cost proportional to the size of BESS. The annualized on-time BESS cost (AOTC) can be determined as

$$AOTC = \frac{r(1+r)^l}{(1+r)^l - 1} * FC * CE$$

where  $FC$  is the one-time BESS cost,  $CE$  is the size of BESS.  $l$  is the lifetime of the BESS in years,  $r$  is the interest rate for financing the installed BESS.

- The total cost of BESS can be obtained by adding  $AOTC$  and the annual maintenance cost ( $MC$ ) together. The total cost per day (TCPD) of the BESS can be determined as

$$TCPD = \frac{1}{365} (AOTC + CE * MC)$$

# Battery Energy Storage Systems



UNIVERSITY OF LEEDS

## Example of battery storage requirement calculation – Islanded Microgrids

Minimum size for BESS needed by the islanded microgrid:

$$\left\{ \begin{array}{l} E_{dis}^{min} = \int_0^T (P_{load}^t - P_{grid}^{t,max}) \delta t, \quad P_{load}^t \geq P_{grid}^{t,max} \\ E_{ch}^{min} = \int_0^T (P_{grid}^{t,min} - P_{load}^t) \delta t, \quad P_{grid}^{t,min} \geq P_{load}^t \\ E_{BESS}^{min} = \max\left(\frac{E_{dis}^{min}}{\eta_d}, \eta_c E_{ch}^{min}\right) \end{array} \right.$$

Where  $T$  is the end of the time period set,  $\delta t$  is the time interval.  $P_{load}^t$  is the system load at time  $t$ ,  $P_{grid}^{t,max}$  is the maximum power supplied by all the generators,  $P_{grid}^{t,min}$  is the minimum power supplied by the renewable energy sources.  $E_{dis}^{min}$  is the minimum energy supplied by the BESS and  $E_{ch}^{min}$  is the minimum energy charged to the BESS.  $E_{BESS}^{min}$  is the minimum size needed by the islanded microgrid.

# Battery Energy Storage Systems



UNIVERSITY OF LEEDS

## Example of battery storage requirement calculation – Islanded Microgrids

Minimize the total unit commitment schedule cost (TUCC):

$$\text{Min: } \sum_t \sum_{n \in CG} (r_n R_{tn} + d_n S U_{tn} + U_{tn} (a_n + b_n P_{tn})) + \sum_t \sum_{n \in WG} (U_{tn} P_{tn} c_w) + \sum_t \sum_{n \in PG} (U_{tn} P_{tn} c_{pv})$$

where  $CG$  is a set of dispatchable distributed generators.  $WG$  and  $PG$  are the sets of wind energy and PV renewable resources, respectively.  $n$  and  $t$  are subscripts indicating generator/energy resource and hour index, respectively.  $a_n$  and  $b_n$  are the cost coefficients of microturbines and fuel cells.  $U_{tn}$  and  $S U_{tn}$  are vectors of binary integers representing unit status and start up status.  $r_n$  and  $d_n$  are the reserve cost and start up cost respectively.  $P_{tn}$  is the generator output power,  $R_{tn}$  is the spinning reserve of dispatchable distributed generators.  $c_w$  and  $c_{pv}$  are wind and PV energy cost, respectively.

# Battery Energy Storage Systems



UNIVERSITY OF LEEDS

## Example of battery storage requirement calculation – Grid-Connected Microgrids

- *Profit = Revenue – Expenses*
- *Revenue*: the energy supplied to the consumers multiplied by the electrical price.
- *Expenses*: the total unit commitment cost (TUCC).
- Maximize the market benefit (MB):

$$\text{Max: } MB = \sum_t \left( MP_t \sum_{n \in CG} P_{tn} \right) - TUCC$$

where  $MP_t$  is the market price, TUCC includes the dispatchable generator costs (start-up cost, online spinning reserve cost, and generating energy cost) and renewable energy cost (wind and PV energy cost).

# Battery Energy Storage Systems



UNIVERSITY OF LEEDS

## Example of battery storage requirement calculation – Optimization

Considering the BESS' total cost per day (TCPD) for both islanded and grid-connected microgrids, the objective function will change to **minimizing** the total cost (TC) for islanded microgrid and **maximizing** the total benefit (TB) for grid –connected microgrid.

$$\begin{cases} \text{Min: } TC = TCPD + TUCC \\ \text{Max: } TB = MB - TCPD \end{cases}$$

Thus, the battery energy storage size requirement can be determined via different optimization techniques.

# Battery Energy Storage Systems



## Case Study - Alderney Island:

- Alderney Island is the third largest of the Channel Islands.
- Permanent resident population  $\approx$  2000 residents.
- Electric power is centrally generated by diesel generators (eight 450kW generators).
- Renewable energy sources include wind energy and solar energy.

Power profile of a representative day

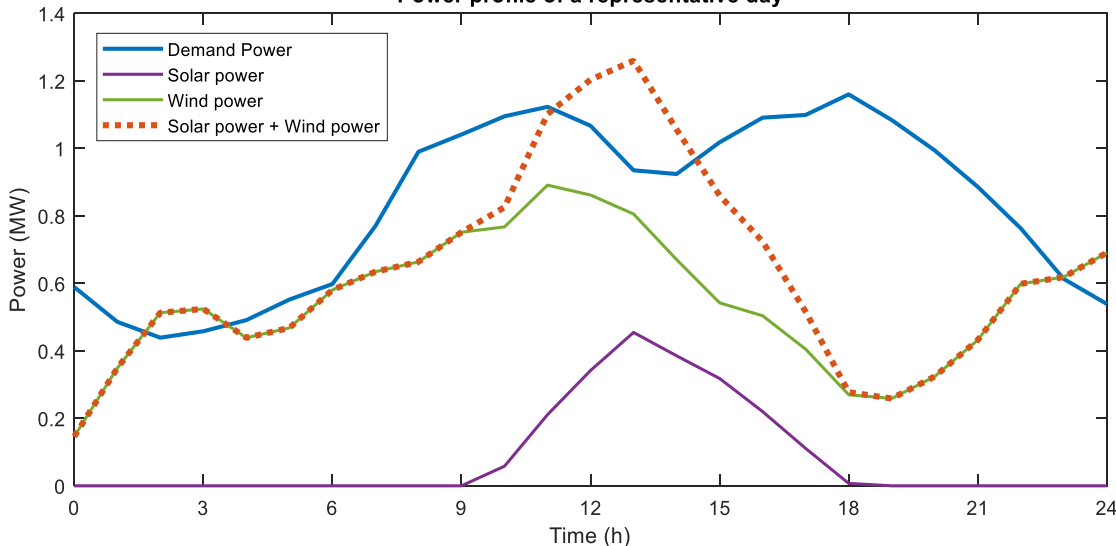

## Goal:

- ✓ Utilize BESS to absorb the excess power from renewable energy sources, and meet the load demand.
- ✓ Minimize the total cost (BESS investment cost + generator operating cost).
- ✓ Determine the size of the BESS.

# Battery Energy Storage Systems



UNIVERSITY OF LEEDS

## Case Study – Technical requirements:

- When the power generated by the renewable energy sources is **greater** than the load demand, the BESS operates in the charging mode to absorb all the excess power.

- If  $P_w(t) + P_s(t) > P_L(t)$  :

$$\begin{cases} P_w(t) + P_s(t) = P_{b,c}(t) + P_L(t) \\ C(t+1) = C(t) + \Delta t P_{b,c} \eta_c \end{cases}$$

- When the power generated by the renewable energy sources is **less** than the load demand the BESS operates in the discharging mode (with the diesel generators) to meet the load demand.

- If  $P_w(t) + P_s(t) < P_L(t)$ :

$$\begin{cases} P_w(t) + P_s(t) + P_g(t) + P_{b,d}(t) = P_L(t) \\ C(t+1) = C(t) - \Delta t P_{b,d} / \eta_d \end{cases}$$

- The BESS must **NEVER** be over-charged or over-discharged:

$$0 \leq C(t) \leq CE$$

- $P_w$ : wind power.
- $P_s$ : solar power.
- $P_g$ : Power generated by the diesel generators.
- $P_L$ : Load demand.
- $P_{b,c}$ : BESS charging power.
- $P_{b,d}$ : BESS discharging power.
- $C(t)$ : energy stored in the BESS at time t.
- $\Delta t$ : Time duration,  $\Delta t = 1$  hour in this case study.
- $\eta_c$ : BESS charge efficiency,  $\eta_c$  is assumed as 1 in this case study.
- $\eta_d$ : BESS discharge efficiency,  $\eta_d$  is assumed as 1 in this case study.
- CE: the battery size needs to be determined.

# Battery Energy Storage Systems



## Case Study – Financial requirements:

Daily total Cost (DTC) = BESS daily levelized investment cost + daily diesel generators operating cost.

Daily levelized investment cost (DLIC) of the BESS:

$$DLIC = \frac{1}{365} * \frac{r(1+r)^L}{(1+r)^L - 1} * IC * CE$$

Daily diesel generators operating cost (DGOC):

$$DGOC = \int_{t=0}^{24} P_g(t) * GOC$$

To minimize the daily total cost,

$$\text{Min: } DTC = DLIC + DGOC$$

Various solvers can be used to solve this linear programming problem, e.g., YALMIP and *linprog* toolbox in MATLAB.

### Parameters:

- BESS investment cost ( $IC$ ) = 0.98 M£ / MWh
- The life time of the BESS ( $L$ ) is assumed as 15 years.
- The operation costs of the BESS is assumed as 0.
- The interest rate ( $r$ ) is assumed as 0.053.
- The generators operating cost (GOC): 196.2 £ /MWh.
- The line resistance and reactance are assumed as 0 in this case study.

# Battery Energy Storage Systems

## Case Study – Results analysis:

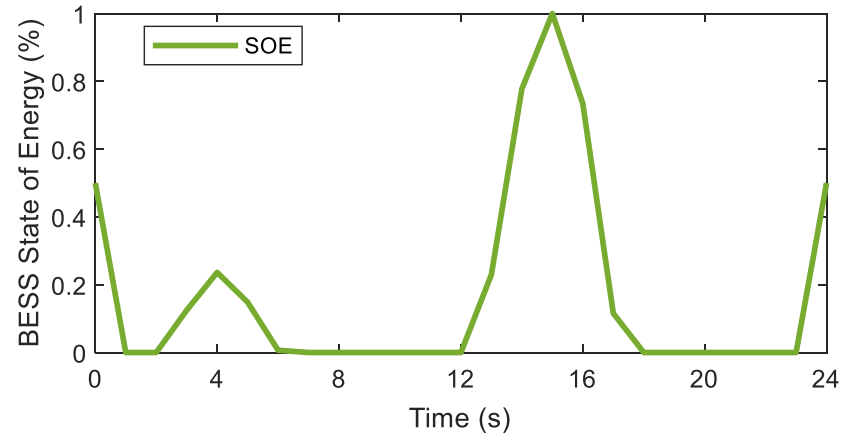
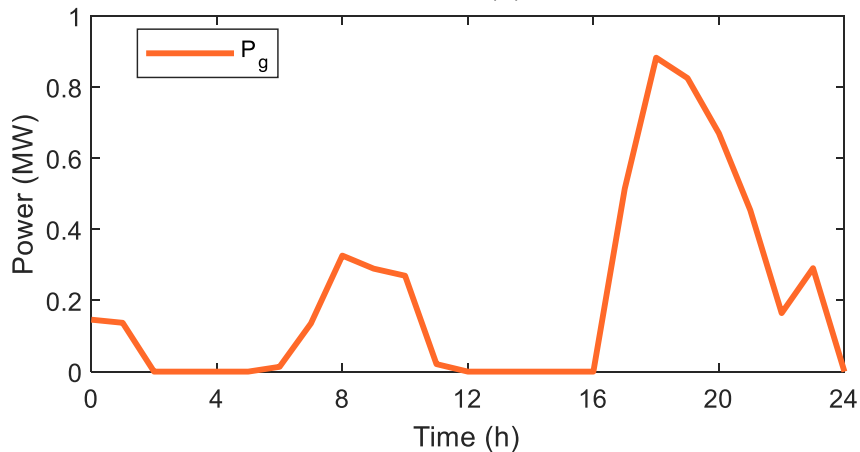
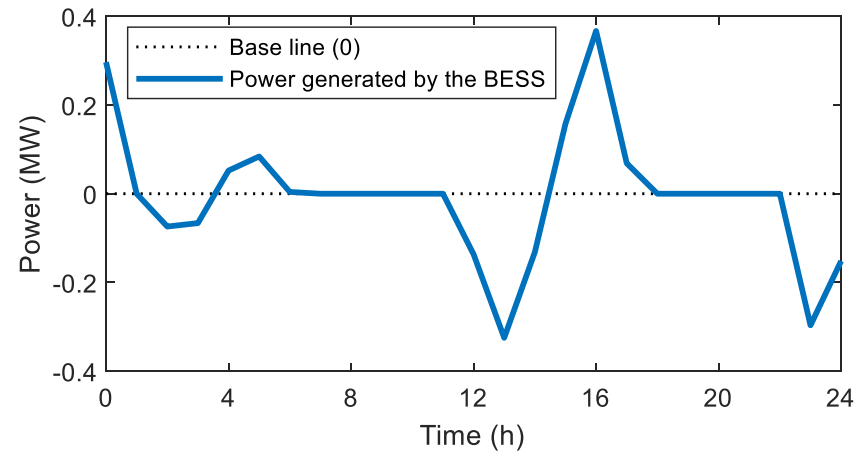
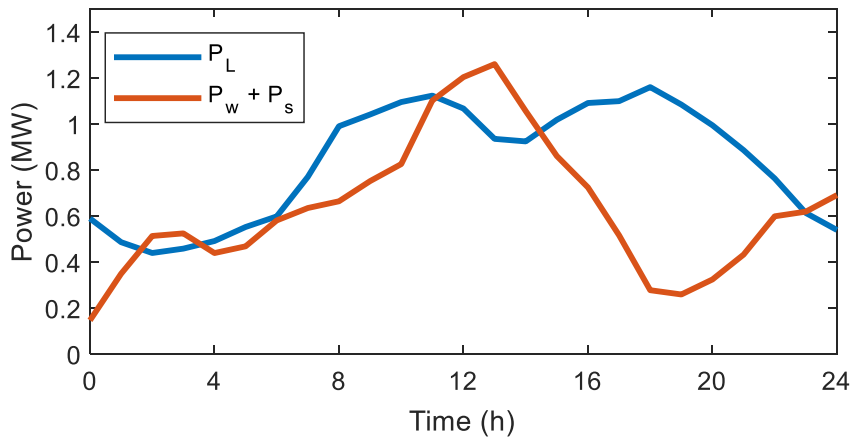

The optimal battery size in this case study is determined as 0.59 MWh.

# Battery Energy Storage Systems



UNIVERSITY OF LEEDS

## Case Study Appendix – Power profile:

Time (h)	Load demand (MW)	Solar power (MW)	Wind power (MW)	Time (h)	Load demand (MW)	Solar power (MW)	Wind power (MW)
0	0.5890	0.0000	0.1462	13	0.9350	0.4545	0.8055
1	0.4860	0.0000	0.3488	14	0.9240	0.3854	0.6705
2	0.4390	0.0000	0.5130	15	1.0180	0.3181	0.5422
3	0.4580	0.0000	0.5242	16	1.0910	0.2200	0.5040
4	0.4910	0.0000	0.4388	17	1.0990	0.1109	0.4050
5	0.5520	0.0000	0.4680	18	1.1600	0.0073	0.2700
6	0.5980	0.0000	0.5805	19	1.0840	0.0000	0.2587
7	0.7700	0.0000	0.6345	20	0.9940	0.0000	0.3240
8	0.9900	0.0000	0.6637	21	0.8860	0.0000	0.4320
9	1.0410	0.0000	0.7515	22	0.7630	0.0000	0.5985
10	1.0950	0.0582	0.7673	23	0.6130	0.0000	0.6187
11	1.1230	0.2109	0.8910	24	0.5390	0.0000	0.6908
12	1.0670	0.3418	0.8618				

# Battery Energy Storage Systems



UNIVERSITY OF LEEDS

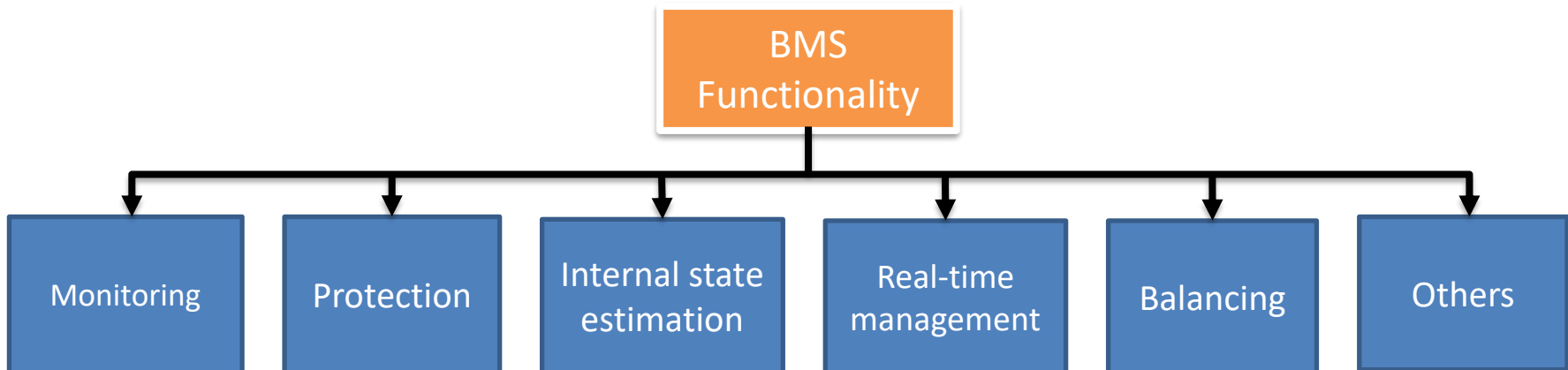
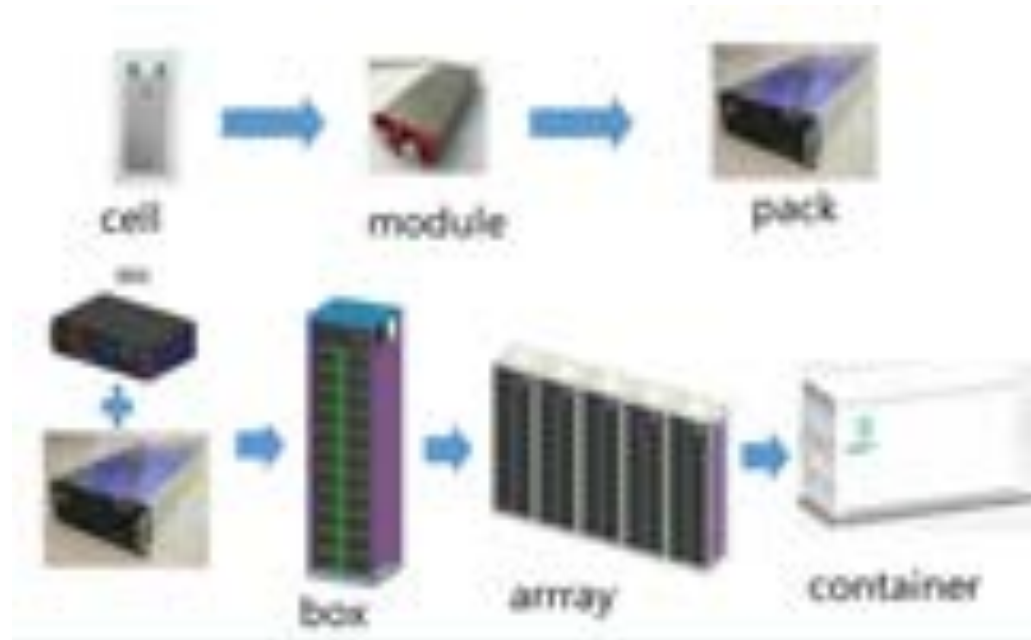

# Battery Energy Storage Systems

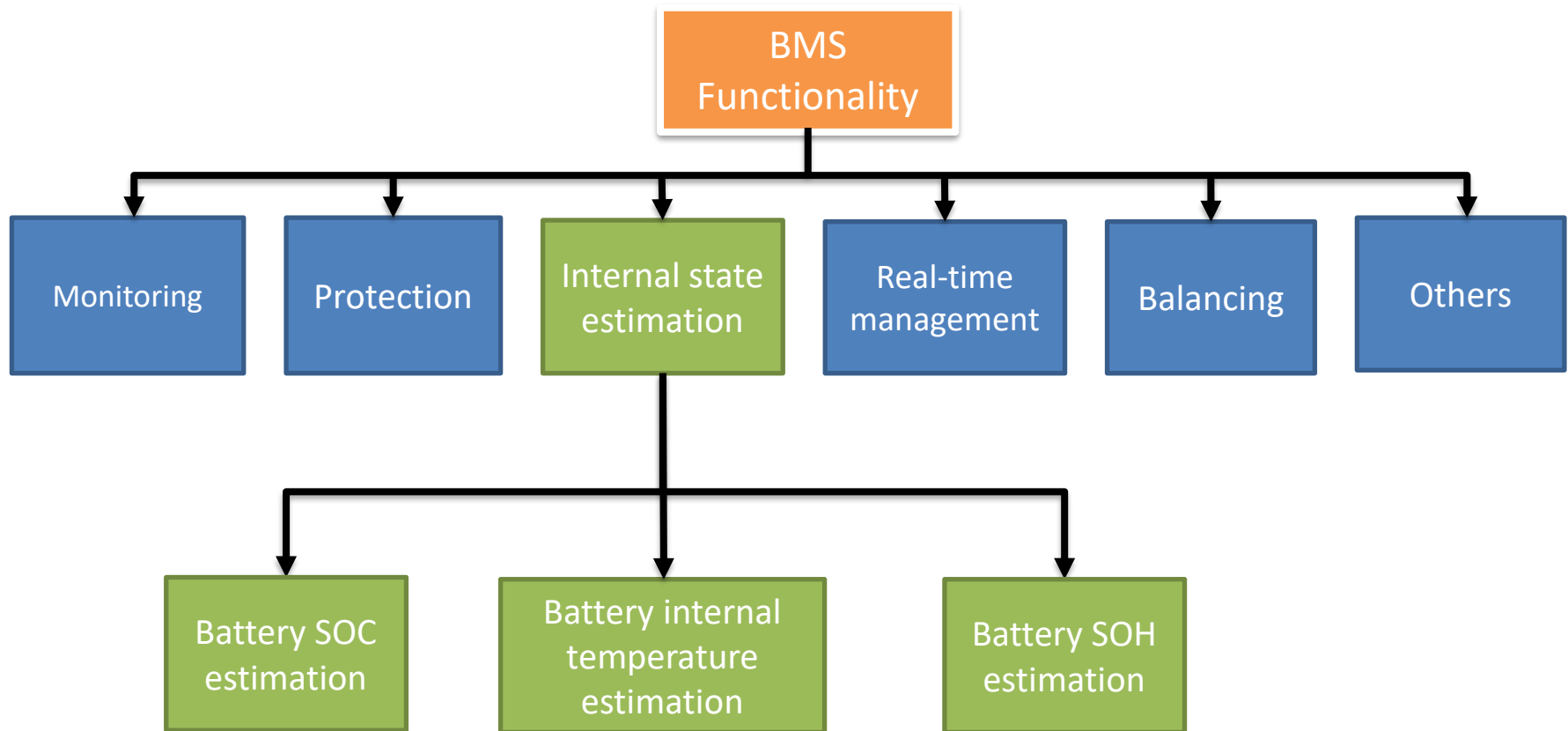

## Battery SOC estimation

- **Coulomb counting method**

$$SOC(k) = SOC(k - 1) + \frac{T_s}{C_n} * i(k - 1)$$

- **OCV-based method**

OCV-SOC one-to-one relationship.

Requirement of long relaxation time.

Hysteresis effect

- **Electrochemical models**

Adapts physical laws.

Complex

Difficult for real-time applications.

- **Black-box models**

Easy to implement.

Requires a large amount of data.

- **Equivalent Circuit Model:**

### First-order RC model

$$V_{t,k} = V_{oc,k} + I_k * R_0 - U_{p,k}$$

$$U_{p,k+1} = -\frac{1}{U_p R_p} U_{p,k} - \frac{1}{C_p} I_k$$

### Second-order RC model

$$V_{t,k} = V_{oc,k} + I_k * R_0 - U_{pa,k} - U_{pc,k}$$

$$U_{pa,k+1} = -\frac{1}{U_{pa} R_{pa}} U_{pa,k} - \frac{1}{C_{pa}} I_k$$

$$U_{pc,k+1} = -\frac{1}{U_{pc} R_{pc}} U_{pc,k} - \frac{1}{C_p} I_k$$

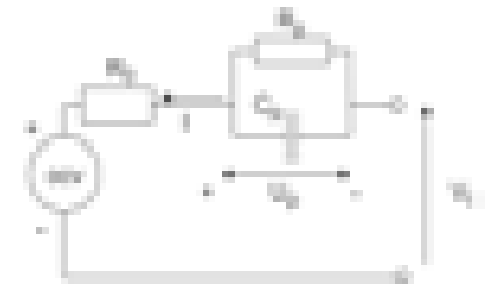

First-order RC model

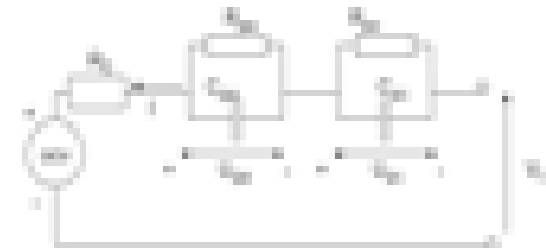

Second-order RC model

## Battery SOC estimation

1. A non-linear complementary model is applied to capture the hysteresis effect.
2. An auto-regression (AR) model is adopted to reproduce the battery terminal behavior

### Hysteresis Model:

$$V_h(k+1) = \exp(-|\gamma * i(k)|) * V_h(k) + (1 - \exp(-|\gamma * i(k)|)) * \text{sign}(i(k)) * M_h$$

### AR model to capture the relaxation effect:

$$V_r(k) = \sum_{i=1}^m a_i * V_r(k-i) + \sum_{i=1}^n b_i * i(k-i) + e(t)$$

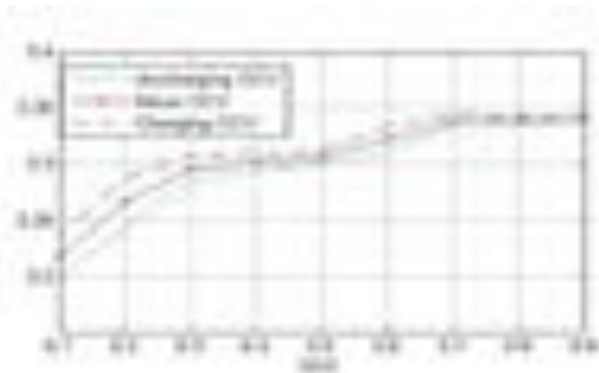

Hysteresis effect of the LiFePO<sub>4</sub> cell

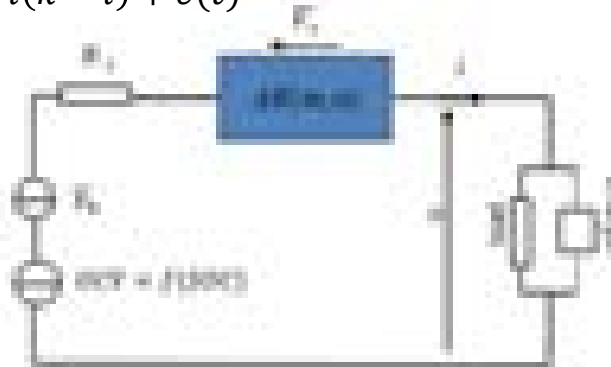

Battery model with AR (m, n) instead of RC networks

$V_h(k)$ : The hysteresis voltage

$i(k)$ : The current

$\gamma$ : The coefficient

$M_h$ : The maximum hysteresis voltage

$\epsilon$ : a small threshold value

$V_r$ : The battery relaxation voltage

$e(k)$ : The error

## Battery SOC estimation

Model identification:

$$V_r(k) = OCV(SOC(k)) - V_h(k) - R_i * i(k)$$

$$\text{Let: } v_a = OCV(SOC(k)) - V_h(k) - v(k),$$

$$v_a = \sum_{i=1}^m a_i * (k - i) + R_i * i(k) + \sum_{i=1}^n (b_i - a_i * R_i) * i(k - i) + e(t)$$

The objective function that is to be optimized is:

$$SSE = \sum_{i=1}^N e^2(t)$$

The model parameters that need to be optimized are:

$$\theta = [a, b, \gamma, M_h, R_i]$$

where  $a = [a_1, a_2, \dots, a_m]$  and  $b = [b_1, b_2, \dots, b_n]$

$V(k)$ : The terminal voltage

$R_i$ : The internal resistance

$N$ : The number of data samples.

# Battery Energy Storage Systems

## Battery SOC estimation

Results:

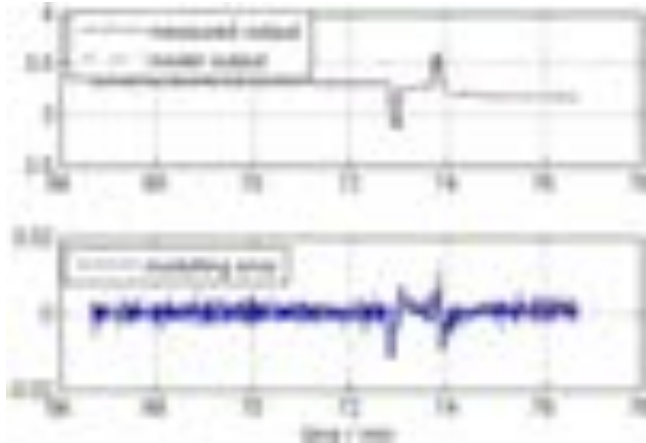

Modelling results using HPPC data

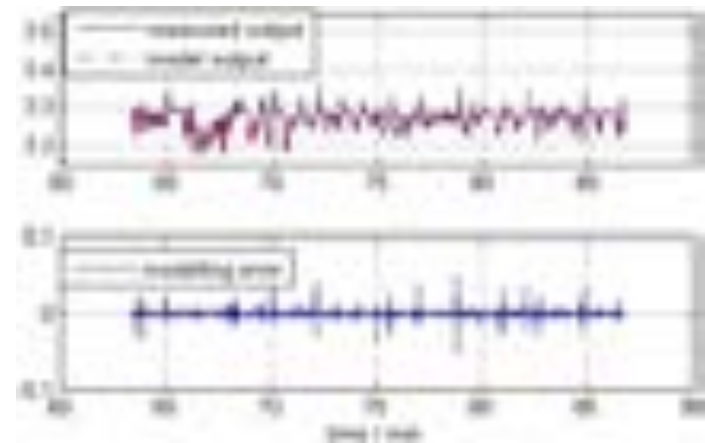

Modelling validation results using FUDS test data

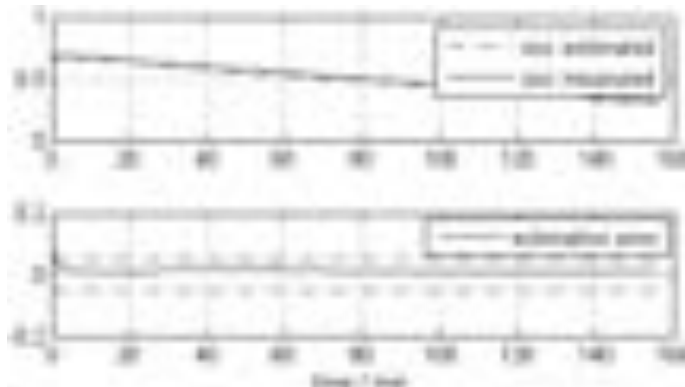

Real-time SOC estimation result

---

RMS of SOC estimation error

---

With 20% initial SOC error                      1.63%

Without initial SOC error                      1.48%

---

## Battery internal temperature estimation

Battery electric circuit model:

$$OCV = f(SOC)$$

$$SOC(k) = SOC(k-1) + i(k-1) * \frac{T_s}{3600 * C_n}$$

$$\text{Let } a_l = \exp\left(-\frac{T_s}{R_l C_l}\right), b_l = R_l * (1 - a_l), l = 1, 2.$$

$$v_l(k) = a_l * v_l(k-1) + b_l * i(k-1)$$

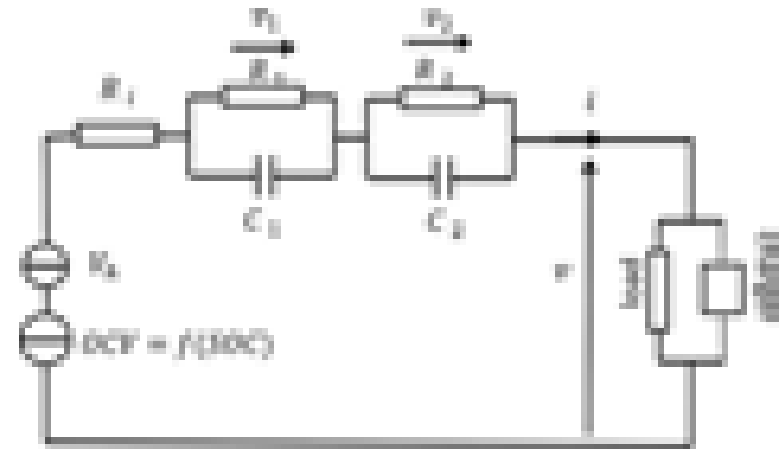

Recall the hysteresis dynamic model:

$$V_h(k) = \exp(-|\gamma * i(k-1)|) * V_h(k-1) + (1 - \exp(-|\gamma * i(k-1)|)) * \text{sign}(i(k-1)) * M_h$$

Battery electric sub-model:

$$x_e(k) = A_e(k-1) * x_e(k-1) + B_e(k-1), \quad x_e(k) = [SOC(k), v_1(k), v_2(k), V_h(k)]^T$$

$$v = OCV + V_h + R_i * i + v_1 + v_2$$

## Battery internal temperature estimation

### Battery thermal model:

*Simplified heat generation model:*

$$Q_1 = R_i * i^2$$

$$Q_2 = i * (v - OCV)$$

$$Q_3 = i * (v - OCV) + i * T_{in} * \frac{dOCV}{dT_{in}}$$

*Simplified heat transfer model:*

$$C_{in} * \frac{dT_{in}}{dt} = Q_j - k_1 * (T_{in} - T_{sh}), \quad j \in \{1, 2, 3\}$$

$$C_{sh} * \frac{dT_{sh}}{dt} = k_1 * (T_{in} - T_{sh}) - k_2 * (T_{sh} - T_{amb})$$

*Battery thermal sub-model:*

$$x_t(k) = A_t(k-1) * x_t(k-1) + B_t(k-1)$$

where,  $x_t(k) = [T_{in}(k), T_{sh}]^T$

$Q_{1,2,3}$ : heat generation.

$R_i$ : battery internal resistance.

$i$ : current.

$v$ : battery terminal voltage

$T_{in}$ : battery internal temperature.

$T_{sh}$ : battery shell temperature.

$T_{amb}$ : the ambient temperature.

$C_{in}$ : battery internal thermal capacity.

$C_{sh}$ : battery shell thermal capacity.

$k_1$ : the heat conduction coefficient between the battery internal and the shell.

$k_2$ : the heat conduction coefficient between the battery shell and the ambience.

## Battery internal temperature estimation

### Coupled thermoelectric model:

$$x(k) = A(k - 1) * x(k - 1) + B(k - 1)$$

$$v(k) = f_{ocv}(SOC(k)) + V_h(k) + v_1(k) + v_2(k) + R_i * i(k)$$

where:

$$x(k) = [x_e(k), x_t(k)]^T$$

$$A(k - 1) = blkdiag(A_e(k - 1), A_t(k - 1))$$

$$B(k - 1) = [B_e(k - 1), B_t(k - 1)]^T$$

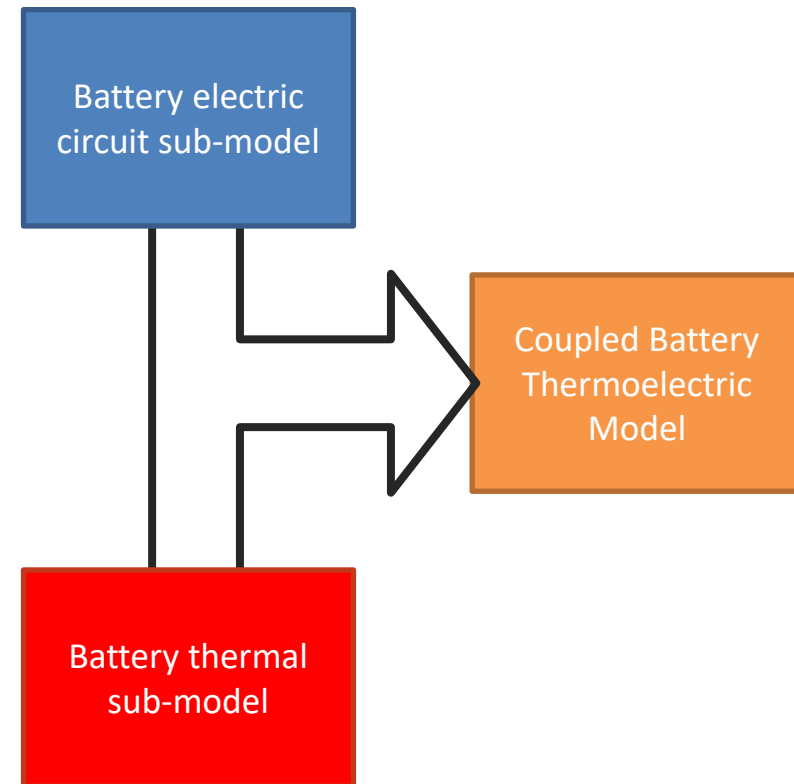

## Battery internal temperature estimation

Modelling results:

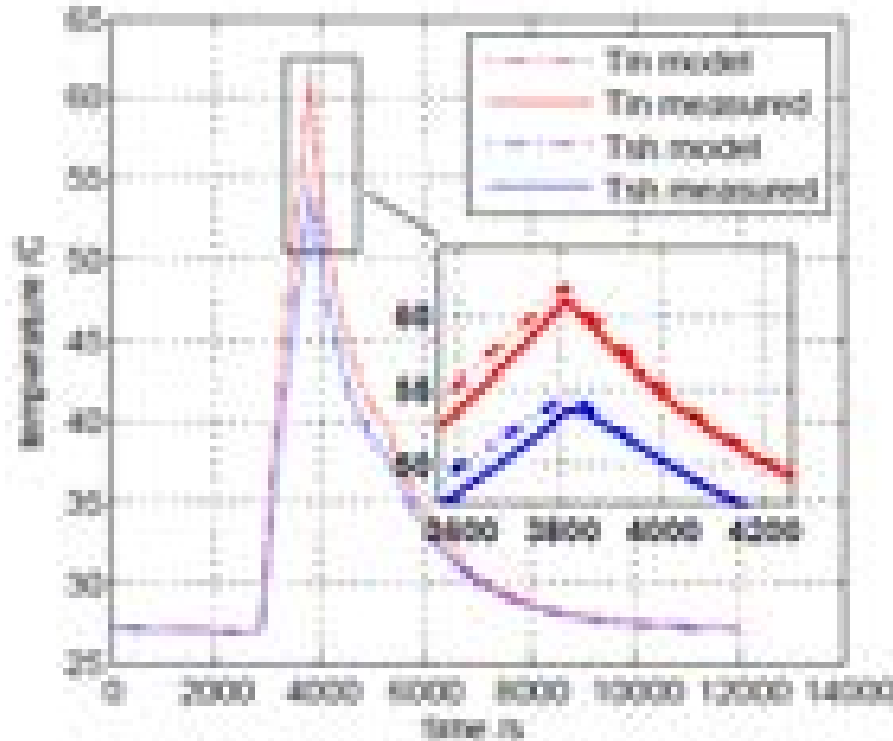

Thermal modelling results

Thermal sub-model identification results

Parameters	Value
$C_{in}$	288.77
$C_{sh}$	30.8
$k_1$	1.7312
$k_2$	0.3205

Thermal modelling results

Item	Error
$T_{in}$ Max error	1.51
$T_{in}$ RMSE	0.695
$T_{sh}$ Max error	2.31
$T_{sh}$ RMSE	0.714

## Battery SOH Estimation

Comparison of Several Popular SOH Estimation Methods

Methods	Description	Advantages	Disadvantages
Model-free (Physical Measurement)	$SOH = \frac{C_{actual}}{C_{nominal}} \times 100\%$ $SOH = \frac{R_{actual}}{R_{nominal}} \times 100\%$	<ul style="list-style-type: none"><li>• Easy to implement</li><li>• Excellent precision</li></ul>	<ul style="list-style-type: none"><li>• Standard battery capacity and internal resistance tests are required.</li><li>• Time consuming.</li></ul>
Electrochemical methods	Fitting the parameters of the physical equations.	<ul style="list-style-type: none"><li>• High accuracy and reliability</li></ul>	<ul style="list-style-type: none"><li>• Complex</li><li>• Difficult for real-time application</li></ul>
ECM based methods	Using electric components to represent battery behaviour, calculate SOH according to other battery internal states, e.g. SOC.	<ul style="list-style-type: none"><li>• Easy for on-board application.</li><li>• No sophisticated experiments are required.</li></ul>	<ul style="list-style-type: none"><li>• Requires filters to improve the adaptability</li></ul>
Semi-empirical based models	Modelling each aging factor according to physical laws and experience knowledge.	<ul style="list-style-type: none"><li>• High accuracy</li><li>• High prediction ability.</li></ul>	<ul style="list-style-type: none"><li>• Require specific designed experiments.</li><li>• Poor adaptability.</li></ul>
Data mining methods	Discovering the ageing patterns in large data sets.	<ul style="list-style-type: none"><li>• Do not require priori knowledge of ageing mechanisms.</li><li>• Input data can be easily obtained.</li></ul>	<ul style="list-style-type: none"><li>• Requires a large amount of data.</li></ul>

## Battery SOH Estimation

### Battery capacity

- Accurate capacity estimation provides insights into the SOH, thus plays a critical role in BMS, ensuring safe and reliable battery operation, preventing incipient failures and catastrophic hazards, and prolonging the battery service life.

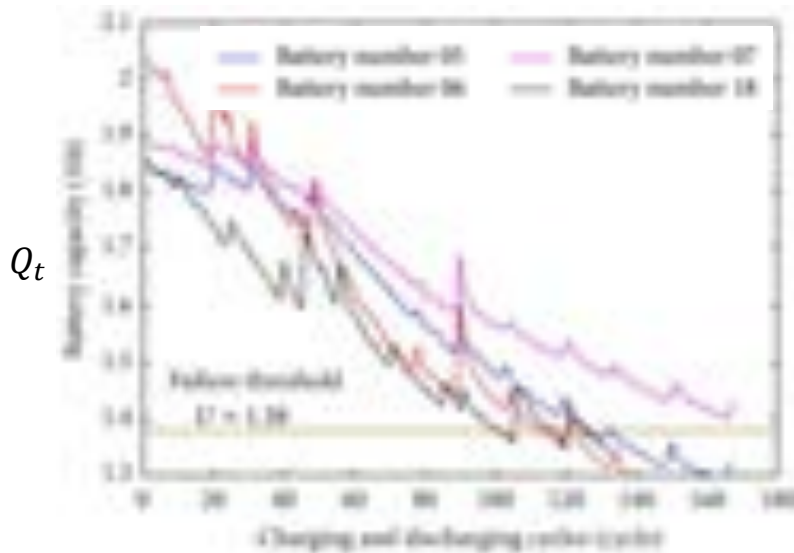
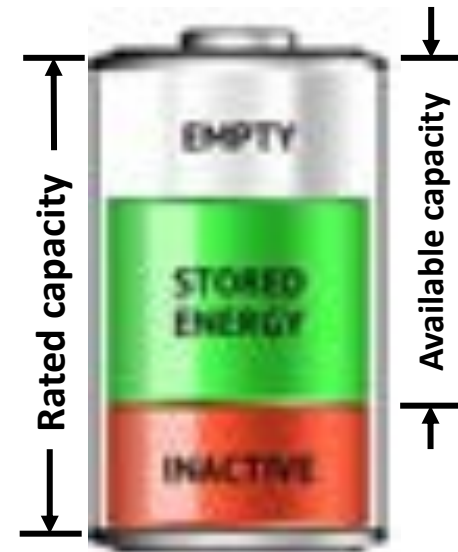

$$SOH = \frac{Q_t}{Q_{rated}} \times 100\%$$

$Q_{rated}$  is the rated capacity of a battery, and  $Q_t$  is the battery's maximum available capacity at current cycle  $t$ .

# Battery Energy Storage Systems



UNIVERSITY OF LEEDS

- CNN is a neural network with convolution operation instead of matrix multiplication in at least one of the layers. A convolutional layer has several filters (also called kernel, weight matrix or feature detector) that does convolutional operation.
- Compared with traditional deep neural networks (DNNs), the number of parameters (weights) of a CNN that are required to maintain the accuracy is significantly reduced, due to three **main concepts** being introduced to the CNNs:

- ✓ Sparse Connectivity
- ✓ Shared Weights
- ✓ Pooling

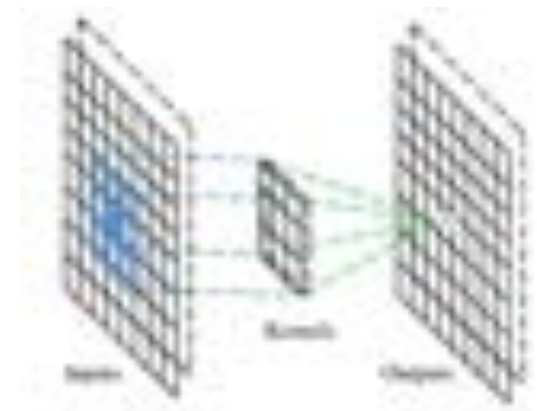
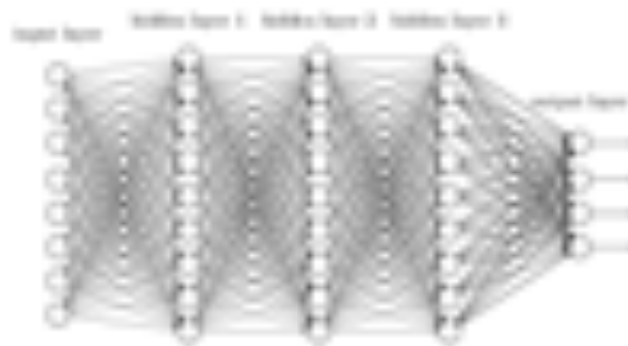

# Battery Energy Storage Systems



UNIVERSITY OF LEEDS

## □ Time Series Signal Transformation

- When apply CNN for battery capacity estimation, a **time series-to-image** transformation process is required
- As illustrated in the figure,  $M$  data chunks with the size of  $n \times 3$  are segmented from a cycle which contains  $L$  data points in total

$$M = \text{floor}\left(\frac{L - n}{n - c}\right) + 1$$

Each data chunk refers to a partial charging segment, 3 is the number of variables (current, voltage, surface temperature), and  $n$  is the number of data points. Two adjacent data chunks have  $c$  overlapping data points. The function  $\text{floor}(\cdot)$  gives the greatest integer less than or equal to the input parameter.

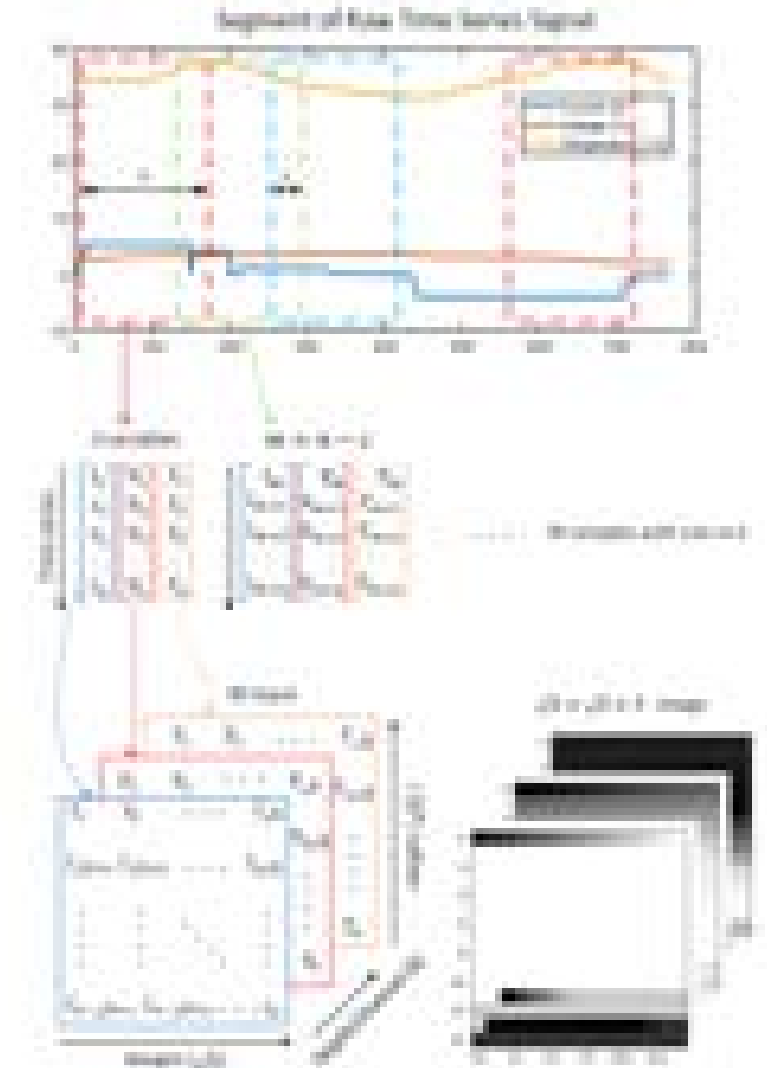

# Battery Energy Storage Systems



UNIVERSITY OF LEEDS

## □ CNN Model Construction for Battery Capacity Estimation

- The CNN architecture for capacity estimation consists of two alternating convolutional and pooling layers, followed by two convolutional layers, and finally a flatten layer and two fully connected layers are utilized.

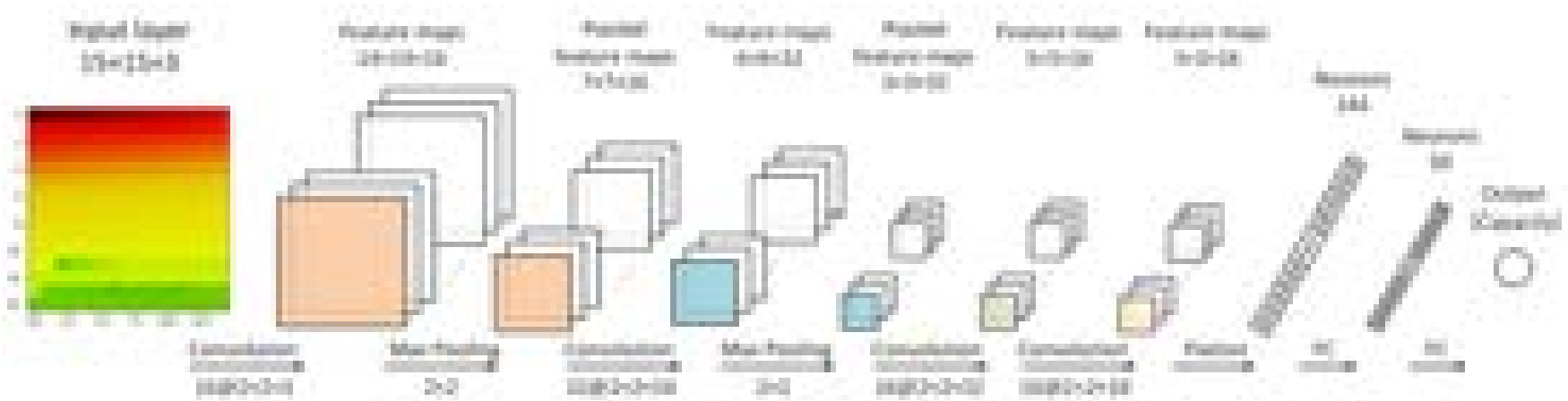

# Battery Energy Storage Systems



UNIVERSITY OF LEEDS

## □ Experiment and Analysis

- **Battery degradation datasets**

The proposed CNN-based capacity estimation method is applied to two battery experimental datasets.

Dataset	124 commercial cells	Oxford Battery Degradation Dataset
Nominal capacity	1.1 Ah	0.74 Ah
Ambient temperature	30 °C	40 °C
Number of cells used in analysis	16	8
Cycling	Cells cycled with similar but different regime	All cells cycled with same regime

# Battery Energy Storage Systems



UNIVERSITY OF LEEDS

## ❑ Limitations

- CNNs typically require large-scale annotated training datasets to achieve high estimation accuracy, while gathering such long-term battery cycling data is often time-consuming and costly.
- Redundant parameters and connections exist in the CNN model.

## ❑ Solutions

- Transfer learning (TL) – improve the accuracy of the CNN model when apply it on a relatively small battery degradation dataset, do not need to build every model from scratch for different types of batteries.
- Network pruning – select the significant neurons and connections, remove those insignificant ones

## □ Transfer learning (TL)

- Neural Network Layers: General to Specific

Earlier layers: extract low-level general features

Later layers: extract high-level specific features

- Process

- Pre-train the CNN model on the source dataset

- Transfer the knowledge learnt from the source dataset to the target dataset

Identify which layers to keep (freeze) and which layers to fine-tune (unfreeze)

- Fine-tune the unfreeze layers of the model on target dataset with smaller learning rate

- Which layers to fine-tune?

- Depends on the size of the target dataset (small or big), and its similarity to the source dataset

# Battery Energy Storage Systems



UNIVERSITY OF LEEDS

❑ **Network Pruning:** aims at removing unimportant connections and reducing the computational complexity for CNN models

• Why?

- ❑ Redundant connections exist in the large CNN model
- ❑ Some neurons are uncorrelated with output
- ❑ Too much parameters in a CNN model

• How?

- ❑ Weight-level
- ❑ Kernel-level
- ❑ Channel-level
- ❑ Layer level

➤ Framework: Evaluate the importance of each weight/kernel/channel/layer, remove those unimportant ones.

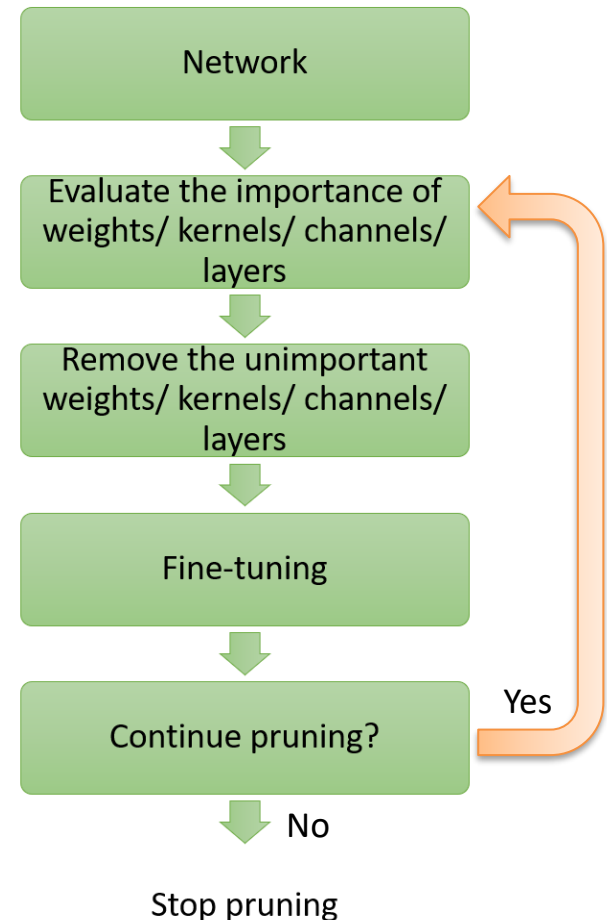
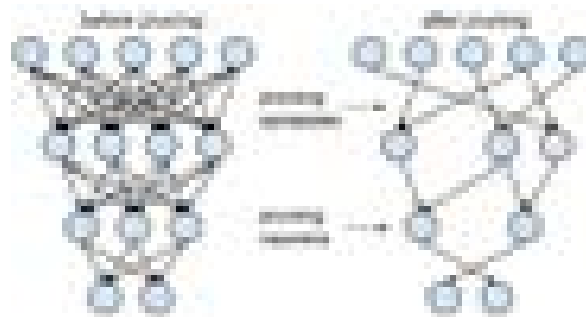

# Battery Energy Storage Systems



UNIVERSITY OF LEEDS

- CNN(T) : train a CNN model on the small target dataset from scratch.
- PCNN(T): pruning unimportant connections from the CNN(T) model.
- CNN(S)-TL: pre-train a CNN(S) model on a large dataset and transfer the learnt knowledge to a small target dataset.
- PCNN(S)-TL: remove unimportant connections from the CNN(S)-TL model.
- Comparing CNN(T) with CNN(S)-TL, the application of transfer learning reduces the average normalized estimation error (NEE) by 22.52%
- Comparing with CNN(T), PCNN(T) and CNN(S)-TL, PCNN(S)-TL achieved 68.34% model size reduction and 80.97% computation savings.

Cell No.	Name	CNN(T)	PCNN(T)	CNN(S)-TL	PCNN(S)-TL
E100	NAME (A)	0.0007	0.0021	0.0012	0.0008
	NAME (A)	0.0018	0.0042	0.0020	0.0010
	NAME (S)	1.00	0.00	0.00	0.00
E102	NAME (A)	0.0007	0.0011	0.0011	0.0008
	NAME (A)	0.0004	0.0014	0.0011	0.0008
	NAME (S)	1.00	0.00	0.00	0.00
E103	NAME (A)	0.0008	0.0020	0.0014	0.0010
	NAME (A)	0.0010	0.0014	0.0008	0.0008
	NAME (S)	1.00	0.00	0.00	0.00
E104	NAME (A)	0.0018	0.0034	0.0010	0.0011
	NAME (A)	0.0008	0.0007	0.0008	0.0007
	NAME (S)	1.00	0.00	0.00	0.00
E105	NAME (A)	0.0007	0.0020	0.0010	0.0008
	NAME (A)	0.0017	0.0008	0.0008	0.0008
	NAME (S)	1.00	0.00	0.00	0.00

# Battery Energy Storage Systems

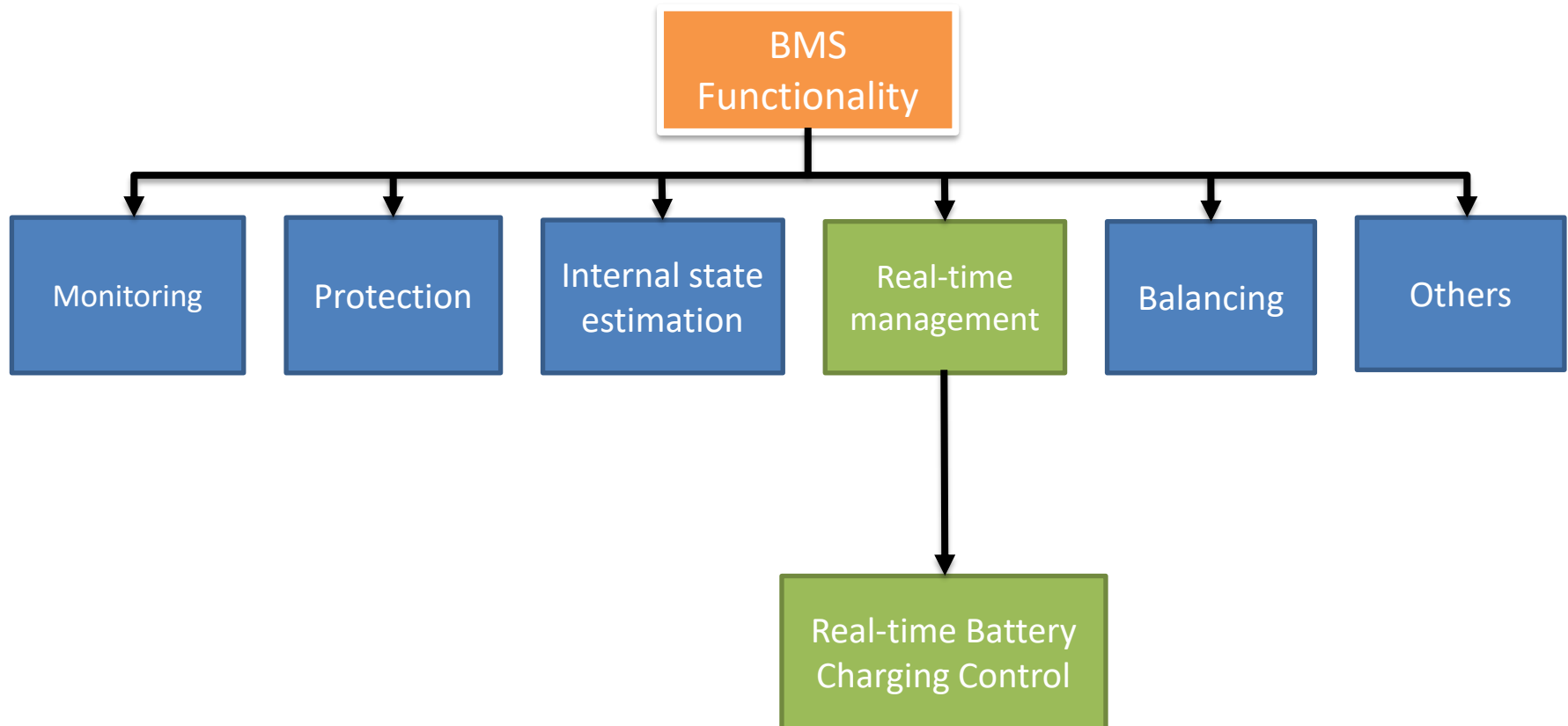

## Battery Real-time Management

Constrained generalised predictive control (GPC) of battery charging process:

### Step 1:

Using the thermoelectric model output to estimate the parameters of the controlled auto-regressive integrated moving average (CARIMA) model.

### Step 2:

Calculate the j-step predictions based on online CARIMA model.

### Step 3:

Find the optimal incremental control current, considering the inequality constraints, extract the first value of the incremental current control sequence.

### Step 4:

Feed the control signal to the actuators.

*CARIMA model:*

$$A(z^{-1})y(k) = z^{-d}B(z^{-1})u(k) + \frac{1}{\Delta}C(z^{-1})\varepsilon(k)$$

*The J-step output:*

$$C(z^{-1})y(k+j, k) = G_j(z^{-1})y(k) + F_j(z^{-1})\Delta u(k+j-1)$$

*The objective function:*

$$J = (1 - a_1) * t_f + a_1 * \int_{t=0}^{t=t_f} i(t) * (V(t) - U_{ocv}(t)) + i(t) * T_{in}(t) * dU_{ocv}(t)/dT_{in}(t)dt$$

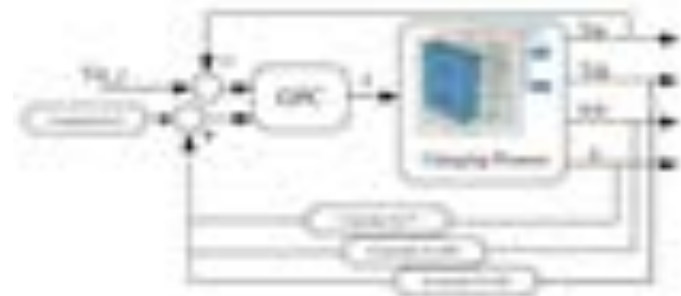

# Battery Energy Storage Systems

## Battery Real-time Management

Simulation results:

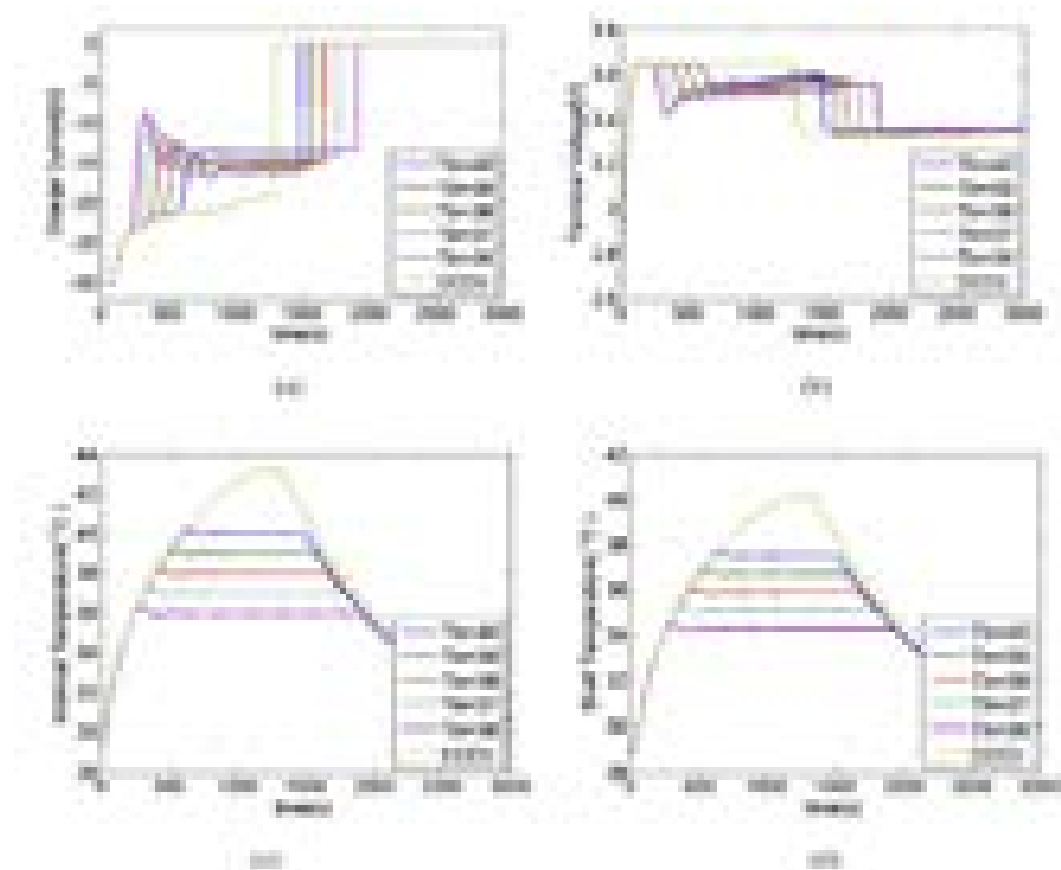

Effects to different internal temperatures

# Battery Energy Storage Systems

## UK Battery Energy Storage Projects in the UK

